



**Operating Manual**  
**TG5000 Gas Monitor**



Order No.: 10212126/03

Print Spec: 10000005389 (EO)

CR: 800000073622

## **WARNING!**

Read this manual carefully before using or maintaining the device. The device will perform as designed only if it is used and maintained in accordance with the manufacturer's instructions. Otherwise, it could fail to perform as designed, and persons who rely on this device could sustain serious injury or death.

The warranties made by MSA with respect to the product are voided if the product is not installed and used in accordance with the instructions in this manual. Please protect yourself and your employees by following the instructions.

Please read and observe the WARNINGS and CAUTIONS inside. For additional information relative to use or repair, call 1-800-MSA-2222 during regular working hours.

For countries of Russian Federation, Republic of Kazakhstan and Republic of Belarus, the gas detector will be delivered with a passport document that includes valid approval information. On the CD with manual instruction attached to the gas detector the user will find the documents "Type Description" and "Test Method" - appendixes to Pattern Approval Certificate of Measuring instrument, valid in the countries of use.

The Declaration of Conformity can be found under the following link: <https://MSAsafety.com/DoC>.

MSA is a registered trademark of MSA Technology, LLC in the US, Europe and other Countries. For all other trademarks visit <https://us.msasafety.com/Trademarks>.

This device complies with part 15 of the FCC Rules. Operation is subject to the following two conditions: (1) This device may not cause harmful interference, and (2) this device must accept any interference received, including interference that may cause undesired operation.

You are cautioned that changes or modifications not expressly approved by the party responsible for compliance could void the user's authority to operate the equipment.

### **English:**

This device complies with RSS-210 of the Industry Canada Rules. Operation is subject to the following two conditions: (1) This device may not cause harmful interference, and (2) this device must accept any interference received, including interference that may cause undesired operation.

### **French:**

Ce dispositif est conforme à la norme CNR-210 d'Industrie Canada applicable aux appareils radio exempts de licence. Son fonctionnement est sujet aux deux conditions suivantes: (1) le dispositif ne doit pas produire de brouillage préjudiciable, et (2) ce dispositif doit accepter tout brouillage reçu, y compris un brouillage susceptible de provoquer un fonctionnement indésirable.



*The Safety Company*

1000 Cranberry Woods Drive  
Cranberry Township, PA 16066  
USA  
Phone 1-800-MSA-2222  
Fax 1-800-967-0398

For your local MSA contacts, please go to our website [www.MSAsafety.com](http://www.MSAsafety.com)

# Contents

<b>1</b>	<b>Safety Regulations</b> .....	<b>4</b>
1.1	Correct Use .....	4
1.2	Product Warranty .....	5
<b>2</b>	<b>Description</b> .....	<b>6</b>
2.1	Display .....	6
2.2	No Tool Interface .....	6
2.3	Bluetooth Wireless Technology .....	6
2.4	Dual Sensing .....	7
2.5	XCell Sensors Optimized for Fixed Gas Applications .....	7
2.6	TruCal Sensing Technology for CO and H2S Electrochemical Sensors .....	7
2.7	SafeSwap .....	8
2.8	Housing .....	8
2.9	Label Overview .....	8
<b>3</b>	<b>Installation</b> .....	<b>10</b>
3.1	Installation Warnings - Read Before Installation .....	10
3.2	Product Installation Check List .....	10
3.3	Mounting .....	11
3.4	Electrical Power Connections .....	18
3.5	Internal Power Supply .....	24
<b>4</b>	<b>Operation</b> .....	<b>24</b>
4.1	Startup .....	24
4.2	Settings .....	25
4.3	Status Menu .....	38
<b>5</b>	<b>Calibration</b> .....	<b>38</b>
5.1	Calibration Equipment .....	39
5.2	Calibration Frequency .....	40
5.3	Calibration Frequency for XCell Sensors with TruCal and Diffusion Supervision (H2S & CO only) .....	40
5.4	Calibration Frequency for XCell Sensors with TruCal without Diffusion Supervision (H2S & CO only) .....	40
5.5	Calibration Types: Zero vs. Span .....	40
5.6	How to Zero Calibrate XCell Sensors .....	41
5.7	How to Calibrate XCell Sensors .....	42
5.8	How to Calibrate an Oxygen XCell Sensor .....	43
5.9	How to Calibrate an XIR PLUS Sensor .....	43
5.10	XCell Catalytic Bead LOC Over Range .....	43
5.11	Calibration Confirmation and As Found / As Left Values .....	44
<b>6</b>	<b>Maintenance</b> .....	<b>44</b>
6.1	ULTIMA XIR PLUS Cleaning Procedure .....	44
6.2	Replacing an XCell Sensor .....	45
6.3	Clearing a Blockage .....	46
6.4	Troubleshooting .....	47
<b>7</b>	<b>Ordering Information</b> .....	<b>51</b>
7.1	Replacement Parts .....	51
7.2	Accessories .....	52
<b>8</b>	<b>Appendix: Specifications</b> .....	<b>53</b>
<b>9</b>	<b>Appendix: Calibration Guide for Additional Gases</b> .....	<b>54</b>
<b>10</b>	<b>Appendix: HART Specific Information</b> .....	<b>58</b>
<b>11</b>	<b>Appendix: Modbus RTU Protocol Operation</b> .....	<b>60</b>
11.1	Baud Rate .....	60
11.2	Data Format .....	61
<b>12</b>	<b>Appendix: System and Sensor Part List</b> .....	<b>62</b>

### NOTICE

All units manufactured prior to December 01, 2025 must refer to this products previous manual revision 02. These TG 5000 units can be identified by the silver front panel. Whereas the new units have a black front panel. The previous manual revisions can be found on the [MSASafety.com](https://www.msasafety.com) TG 5000 product page.

## 1 Safety Regulations

### 1.1 Correct Use

The TG5000 Gas Monitor, hereafter also called device, is a gas monitor for measuring toxic and combustible gases as well as oxygen. Using sensors, the device tests the ambient air and triggers the alarm as soon as the gas exceeds a specific concentration level.

### WARNING!

- The TG5000 Gas monitor is designed for installation in general purpose areas.
- Do Not install in a hazardous location.
- The TG5000 has not been certified for performance by any approval agency and therefore should be used for monitoring purposes only.
- It is the responsibility of the user to ensure compliance with all applicable certifications, markings and regulations.

**Failure to follow this warning can result in serious personal injury or death.**

The TG5000 reference label can be found on the left side of TG5000 Enclosure. (See *Figure 3* for example label)

### WARNING!

- Do not use silicone-type lubricants in assembling the device and do not allow silicone vapors to be drawn into the flow system while in operation. Silicone can desensitize the combustible gas sensor, thereby giving erroneously low readings.
- Use only genuine MSA replacement parts when performing any maintenance procedures provided in this manual.

**Failure to follow these warnings can result in serious personal injury or death.**

This device complies with Part 15 of the FCC Rules. Operation is subject to the following two conditions:

- device may not cause harmful interference, and
- device must accept any interference received, including interference that may cause undesired operation.

This equipment has been tested and found to comply with the limits for a Class A digital device, pursuant to Part 15 of the FCC Rules. These limits are designed to provide reasonable protection against harmful interference when the equipment is operated in a commercial environment. This equipment generates, uses, and can radiate radio frequency energy and, if not installed and used in accordance with the instruction manual, may cause harmful interference to radio communications. Operation of this equipment in a residential area is likely to cause harmful interference in which case the user will be required to correct the interference at the user's expense.

### NOTICE

- This is a Class A product in accordance with CISPR 22. In a domestic environment, this product may cause radio interference, in which case the user may be required to take adequate measures.
- The XCell sensor refers to the sensor portion of the Digital Sensor throughout this manual.

### FCC Warning Statements

Changes or modifications not expressly approved by the manufacturer could void the user's authority to operate the equipment.

### Industry Canada (IC) Warning Statements

The installer of this radio equipment must ensure that the antenna is located or pointed such that it does not emit RF field in excess of Health Canada limits for the general population; consult Safety Code 6, obtainable from Health Canada's website [www.hc-sc.gc.ca](http://www.hc-sc.gc.ca).

## 1.2 Product Warranty

ITEM	WARRANTY PERIOD
TG5000 Gas Monitor	MSA warrants that this product will be free from mechanical defects and faulty workmanship for the period specified in this table for each component, provided it is maintained and used in accordance with MSA's instructions and/or recommendations. Guarantee shall not exceed the indicated warranty period plus six months from the date of manufacture.
Main Transmitter Housing and PCBA	2 years from date of shipment.
XCell Sensors	3 years from date of shipment.
XIR PLUS	5 years on electronics. 10 years on IR source bulb.

This warranty does not cover filters, fuses, etc. Certain other accessories not specifically listed here may have different warranty periods. This warranty is valid only if the product is maintained and used in accordance with Seller's instructions and/or recommendations. The Seller shall be released from all obligations under this warranty in the event repairs or modifications are made by persons other than its own or authorized service personnel or if the warranty claim results from physical abuse or misuse of the product. No agent, employee or representative of the Seller has any authority to bind the Seller to any affirmation, representation or warranty concerning this product. Seller makes no warranty concerning components or accessories not manufactured by the Seller, but will pass on to the Purchaser all warranties of manufacturers of such components. THIS WARRANTY IS IN LIEU OF ALL OTHER WARRANTIES, EXPRESSED, IMPLIED OR STATUTORY, AND IS STRICTLY LIMITED TO THE TERMS HEREOF. SELLER SPECIFICALLY DISCLAIMS ANY WARRANTY OF MERCHANTABILITY OR OF FITNESS FOR A PARTICULAR PURPOSE.

### Exclusive Remedy

It is expressly agreed that Purchaser's sole and exclusive remedy for breach of the above warranty, for any tortious conduct of Seller, or for any other cause of action, shall be the replacement at Seller's option, of any equipment or parts thereof, which after examination by Seller is proven to be defective. Replacement equipment and/or parts will be provided at no cost to Purchaser, F.O.B. Seller's Plant. Failure of Seller to successfully replace any nonconforming equipment or parts shall not cause the remedy established hereby to fail of its essential purpose.

### Exclusion of Consequential Damage

Purchaser specifically understands and agrees that under no circumstances will seller be liable to purchaser for economic, special, incidental or consequential damages or losses of any kind whatsoever, including but not limited to, loss of anticipated profits and any other loss caused by reason of non-operation of the goods. This exclusion is applicable to claims for breach of warranty, tortious conduct or any other cause of action against seller.

### 2 Description

#### 2.1 Display

The TG5000 utilizes an Organic LED (OLED) display which is capable of being seen from a distance of up to 50 ft (15 m) depending on conditions. The OLED display provides clear and crisp information in a variety of languages. The gas reading gauge, which wraps around the live reading area, mimics the reading as a percent of full scale and is also used as a progress bar during operations which require a countdown.

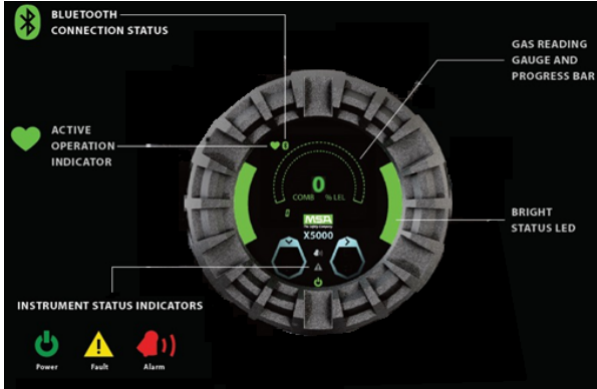

Figure 1 OLED Display

In addition to the OLED display, the TG5000 also employs green, yellow and red LEDs on the side and lower middle of its face. These are used to signal normal operating conditions, fault conditions and alarm conditions.

The TG5000 will go into “Eco-Mode” after 3 minutes of no interaction and if not in an alarm condition. While in Eco-Mode, the main display will power down and the status LED's will remain illuminated to determine that the device is not in an alarm condition. The OLED display can be powered up by touching either of the two EZ touch buttons on the front display.

#### 2.2 No Tool Interface

The TG5000 does not require any tools or third-party devices to change settings, reset alarms or perform any maintenance feature. The EZ touch buttons work through the label and do not require opening the general-purpose enclosure. The EZ touch buttons work with bare fingers or with gloved hands, so long as the gloves are not black. The down arrow is used for scrolling, while the right arrow is used for selecting options. See section 4 for more information on navigating the menu with the EZ touch buttons.



Figure 2 TG5000 Interface

#### 2.3 Bluetooth Wireless Technology

The TG5000 comes standard with Bluetooth enabled. Using the X/S Connect up to 75 feet (23m) away.

**⚠ WARNING!**

Bluetooth Operation is dependent upon signal availability of the wireless service(s) necessary to maintain the communication link for maintenance and configuration. Loss of wireless signal will prevent communication of alarms and other information to linked devices. Take appropriate precautions in the event a loss of wireless signal occurs.

**Failure to follow this warning can result in serious personal injury or death.**

---

**NOTE:** The Bluetooth feature may be disabled following the instructions in [4.2.1 Instrument Settings](#) on disabling Bluetooth.

The TG5000 and user provided communication device will need to be paired. This requires both devices to be in range and for a pairing sequence inputting a 6-digit pairing code. The instructions will be displayed on both the TG5000 and communication device.

---



There are communication devices capable of being used in classified areas. Contact your MSA representative for additional information.

---

## 2.4 Dual Sensing

The TG5000 can communication and display information for two sensors at a time. There are no restrictions to the type of sensors connected to the device. The TG5000 Gas Monitor generates two discrete analog outputs; one for each sensor connected to the transmitter. The analog output associated with Sensor 1 also has the digital HART (Highway Addressable Remote Transducer) communication superimposed on the analog signal. If two sensors are connected, the digital HART communication carries information for both sensors.

## 2.5 XCell Sensors Optimized for Fixed Gas Applications

XCell toxic and combustible cat bead sensors are developed and manufactured by MSA. Now optimized for fixed gas applications, the XCell sensor platform is available in the TG5000 and provides multiple benefits, including a standard 3-year warranty on all XCell sensors. One important optimization for fixed gas was incorporating the GM catalytic bead into the XCell sensor.

The XCell Oxygen sensor does not use lead, but rather a non-consuming reaction chemistry. The XCell Oxygen sensor is expected to last well over 3-years and can be safely stored on the shelf for at least 1 year without sensor performance degradation.

## 2.6 TruCal Sensing Technology for CO and H<sub>2</sub>S Electrochemical Sensors

Using patented pulse check technology and proprietary Adaptive Environmental Compensation (AEC) algorithms, all XCell sensors with TruCal verify operation by actively adjusting the sensor output for changes in sensitivity. Some XCell sensors with TruCal also include Diffusion Supervision, which monitors the sensor inlet for obstructions that could prevent gas from reaching the sensor.

Every six hours, an electrical pulse stimulates the XCell sensor, similar to having actual calibration gas applied, providing a snapshot of the sensor's sensitivity at the time of the pulse. Using this sensitivity snapshot, the sensor can diagnose sensor failures like electrode poisoning, electrolyte leaking, or electrical connectivity issues.

AEC uses the sensitivity snapshots provided by the pulse check to adjust sensor output, compensating for environmental impacts on sensor accuracy. If the AEC adjustment is greater than expected based on typical environmental impact variations, the transmitter LED's will slowly flash GREEN, alerting users that the sensor should be calibrated to reset the AEC cycle. Users can also enable a Calibration Alert function that will send a milli-amp signal on the analog output to the control room. The result is a sensor that actively self-monitors for operation and accuracy, with far fewer manual calibrations.

Diffusion supervision actively monitors the sensor inlet for obstructions. If an obstruction is detected, the sensor will go into a fault mode to alert users and the control room that it is not seeing gas due to an obstruction. Objects residing directly on or in the sensor inlet that result in a significant impact to the gas path are very likely to be detected by Diffusion Supervision. Examples include paint, tape, water, and dirt. Small amounts of these materials can be visible on the inlet while not impacting the gas path enough to trigger a Diffusion Supervision Fault. A fault signal will only be sent out when the system

## 2 Description

determines that the amount of material that has accumulated on or inside the sensor inlet is negatively affecting the gas path.

Actual TruCal sensor performance will depend on the application, background gas exposure, and environment. To validate XCell sensors with TruCal, it is recommended that users follow their regular calibration cycle and record the “as found” and “as left” values. This data can be used to extend the time between calibrations depending on the required specification of the application.

### 2.7 SafeSwap

The TG5000 comes with patented SafeSwap technology, which allows users to change or replace XCell sensors without needing to power down the instrument. For added convenience, the TG5000 comes with Swap Delay enabled by default; a feature that gives users a 2-minute window to change sensors without triggering a fault condition. For more information on SafeSwap and Swap Delay, see [4.2.1 Instrument Settings](#).

#### **WARNING!**

- As part of the product certification, it was verified that optional communication functions of this gas detection instrument while operating at the maximum transaction rate do not adversely affect the gas detection operation and functions of the instrument. The product certification, however, does not include or imply approval of the SafeSwap feature, communications protocol or functions provided by the software of this instrument or of the communications apparatus and software connected to this instrument.
- Follow the warnings below when removing or replacing sensors.
  - Never remove or replace a Sensor Body Assembly or an Ultima XIR PLUS while under power or when explosive hazards are present.
  - Confirm that the area is free of explosive hazards before removing or replacing an XCell Sensor under power.
  - To remove an XCell Sensor, unscrew XCell Sensor three full turns, wait 10 seconds, and then remove the XCell Sensor completely.

**Failure to follow these warnings can result in serious personal injury or death.**

### 2.8 Housing

The TG5000 comes in a polycarbonate housing with integral mounting holes for 10-32 screws in the enclosure base. The enclosure cover must be removed in order to gain access to the mounting holes that are located at the four corners of the enclosure.

### 2.9 Label Overview

System serial number is located where shown inside the TG5000 lid.

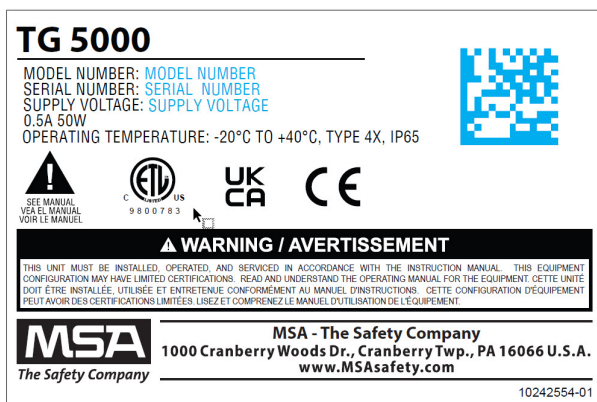

Figure 3 Blank System Serial Number Label

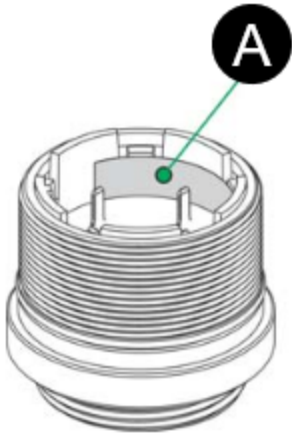

Figure 4 Position of Serial Number Label is located outside enclosure

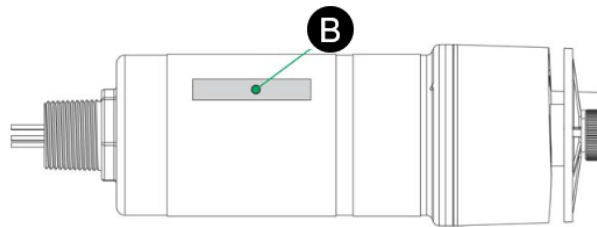

Figure 5 Digital Sensor - Position of ATO Code Label (A)

Figure 6 XIR PLUS - Position of Label (B)

### 2.9.1 Technical Information

Table 1 Specifications

Intended Installation	Indoor or Outdoor, Wet Locations Allowed General Purpose, non-hazardous areas.
Altitude	up to 2000 m
Temperature	-20°C to 40°C (-4°F to 104°F)
Humidity	10-95%, Non-Condensing
Voltage Range	24 VDC +/- 10%
Power Supply	100-256 VAC, 50 Watts
Enclosure Integrity, Ingress Protection	IP65

### 3 Installation

#### 3.1 Installation Warnings - Read Before Installation

##### **WARNING!**

- As part of the product certification, it was verified that optional communication functions of this gas detection instrument while operating at the maximum transaction rate do not adversely affect the gas detection operation and functions of the instrument. The product certification, however, does not include or imply approval of the SafeSwap feature, communications protocol or functions provided by the software of this instrument or of the communications apparatus and software connected to this instrument.
- Follow the warnings below when removing or replacing sensors.
  - Never remove or replace a Sensor Body Assembly or an Ultima XIR PLUS while under power or when explosive hazards are present.
  - Confirm that the area is free of explosive hazards before removing or replacing an XCell Sensor under power.
  - To remove an XCell Sensor, unscrew XCell Sensor three full turns, wait 10 seconds, and then remove the XCell Sensor completely.
- Do not paint the device. Avoid painting in areas where the TG5000 and remote sensor junction box are located. If painting is required in an area where a TG5000 or remote sensor has been installed, exercise caution to ensure paint is not deposited on the sensor inlet fitting. Paint solvents can also cause an alarm condition to occur or potentially poison electrochemical sensors.
- Protect the device from extreme vibration.
- Do not mount the sensing head in direct sunlight without a sunshield.
- The ULTIMA XIR PLUS Sensor contains no user- or field-serviceable parts and must be returned to the factory for repair. Any attempt to open the sensor will damage the unit and void the warranty.

**Failure to follow these warnings can result in serious personal injury or death.**

---

##### **NOTICE**

When installing the XIR PLUS sensor, under no circumstances should a pry-bar be applied to the two legs that support the unit's reflectors during installation or removal of the sensor. Applying force to the legs can permanently damage the XIR PLUS sensor.

#### 3.2 Product Installation Check List

##### 3.2.1 Before Installation

- Review national electrical codes
- Review local procedural and building codes
- Determine optimum transmitter placement
- Determine wire requirements
- Determine mounting hardware requirements
- Review approvals and ensure suitability for installation
- Remove protective shipping film from front of TG5000 before installation

##### 3.2.2 Mounting

- Mount TG5000 to surface using SS mounting bracket kit 10242982. See figure 12. (For proper sensor orientation, see [3.3.4 Sensor Orientation](#))
- Attach internal mounted sensors using installation kit 10242968. [3.3.2 Integral Sensor Mounting](#)
- Attach remote mounted sensors to JB5000 junction box 10213892. See figure 13
- Mount JB5000 junction box using appropriate mounting hardware
- Confirm free air flow around the sensor

### 3.3 Mounting

#### 3.3.1 Remote Sensor Mounting Location

The best location for the transmitter and the sensor may not be the same location. Sensors should be placed in a location where a gas leak is most likely to be detected. When the best sensor placement would not allow the transmitter display to be easily viewed or accessed, a remote junction box can be used to mount the sensor remotely from the transmitter, allowing both to be installed in the optimum location.

Two main factors should be considered when choosing a sensor location. The first is the density of the target gas relative to the air. Gases, such as propane, that are heavier than air should be placed near ground level while gases that are lighter than air should be placed above potential leak sources.

Optimum sensor placement will depend on the surrounding processing equipment, such as pipes, valves, or turbines. MSA offers a gas and flame mapping service that systematically evaluates potential sources of leaks and recommends detector quantity and placement to create the most effective detection system.

The JB5000 junction box must be used with any MSA sensor mounted remotely. Please use part # 10213892 for 3/4" NPT J-Box.

#### 3.3.2 Integral Sensor Mounting



Integral mounted sensors require the use of the sensor installation kit # 10242968. Two are provided with each TG5000, and can also be purchased separately. The backing nut and washer must be installed and firmly tightened.

#### 3.3.3 TG5000 Mounting Location

Mount the TG5000 with the front panel display at or slightly above eye level. View of display must remain unobstructed.

The TG5000 is designed to be used in non-hazardous, general purpose areas, and can be installed indoors or outdoors.. See [8 Appendix: Specifications](#) for additional environmental conditions information.

#### 3.3.4 Sensor Orientation

##### **⚠ WARNING!**

Mount the XIR PLUS with the sensor inlet fitting extended horizontally from the junction box ([Figure 7](#)) to prevent the build-up of particulate or liquid matter on the monitor's optical surfaces. Mount the digital sensor with the sensor inlet fitting ([Figure 8](#)) pointed downward. Otherwise, the inlet may become clogged with particulate matter or liquids and affect the performance of the sensor.

**Failure to follow this warning can result in serious personal injury or death.**

Sensor orientation will depend on the sensor type. When mounting an ULTIMA XIR PLUS sensor via remote junction box, the sensor should be mounted horizontally. If the ULTIMA XIR PLUS sensor is not mounted horizontally, the sensor will be prone to more frequent beam blocking issues due to accumulated dust and condensation on the surface of the ULTIMA XIR PLUS sensor. [Figure 7](#) shows the correct and incorrect mounting orientations for the ULTIMA XIR PLUS.

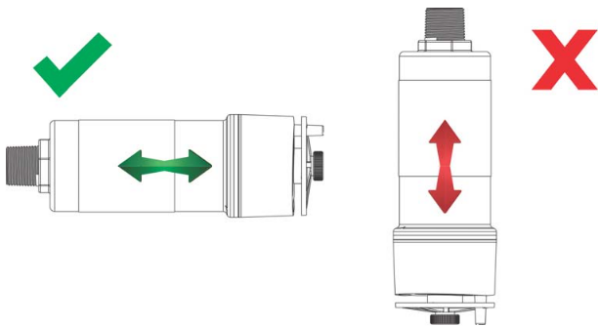

Figure 7 Correct and Incorrect Mounting Orientations for Ultima XIR PLUS Sensor

All other sensors including electrochemical, combustible catalytic bead, and oxygen sensors should be mounted vertically, with the gas inlet pointed downward. If the sensor is not mounted with the gas inlet facing down, it is more likely to become clogged with particulate matter or liquids. Figure 8 shows the correct and incorrect mounting orientation for digital sensors.

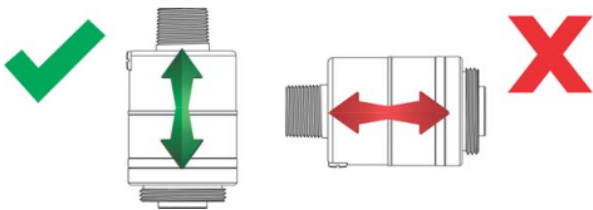

Figure 8 Correct and Incorrect Mounting Orientation for Digital Sensors

#### 3.3.5 Connecting the Sensor to Transmitter Housing or Remote Junction Box

Sensors are not shipped attached to the JB5000 junction box. All sensor modules interface with the transmitter via a digital four-terminal connection. Up to two sensors can be connected to a single transmitter, with each sensor getting a dedicated analog (4-20 mA) output. Consider the sensor dimensions when choosing a mounting location for the transmitter or junction box.

To connect the sensor:

1. Remove the enclosure cover or turn the junction box lid counterclockwise to remove.
2. Pull on the metal bail to remove the board stack and expose wiring connections.
3. Route the cable from the sensor through a conduit entry hole in the enclosure.  
**NOTE:** Repeat to attach a second sensor to the TG5000 transmitter.
4. Connect the sensor to the "Sensor 1" position on the electronics assembly (Figure 9).
5. If using a second sensor, connect it to the "Sensor 2" position.

#### **NOTICE**

If only using one sensor, and it is connected to "Sensor 2" position, the TG5000 will enter Sensor Missing fault. See Disable Sensor in [4.2.2 Sensor Settings](#) for details on how to clear this fault.

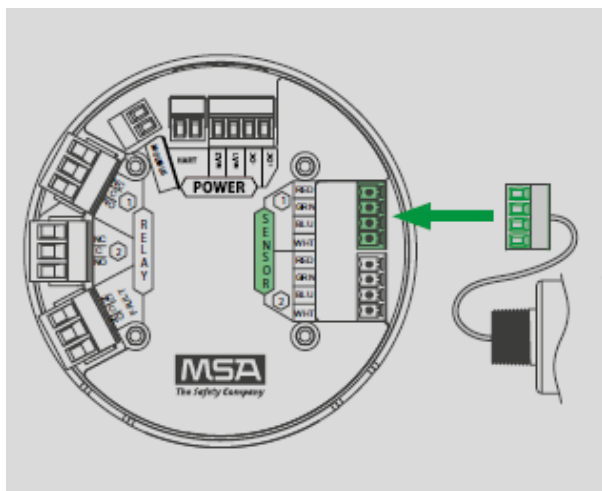

Figure 9 Connecting Sensor to the Stack

**NOTE:** Sensor connectors come pre-wired on the sensor body.

6. Verify the sensor connector is firmly seated on the terminal board.
7. Attach the sensor's ground to either of the grounding screws inside the TG5000 back plate.
8. Replace the board stack legs into the four depressions in the mounting plate. Push firmly on the board stack where indicated (Figure 10).



Figure 10 Highlighted Areas Show Where to Press when Replacing a Board Stack

#### **NOTICE**

Avoid pressing on the left and right areas where the LEDs are located. Pressing directly on the display will damage the display and will void the warranty. Ensure that the electronics assembly is fully engaged in the mounting holes. If not fully seated, the user interface buttons may not function properly.

9. Replace the enclosure cover.

### 3.3.6 TG5000 Mounting Points

The TG5000 transmitter can be mounted with or without any additional brackets using the integrated mounting holes. Clearance holes for 10-32 screws. See [Figure 11 Internal Mounting Holes](#) for mounting hole location.

### 3 Installation

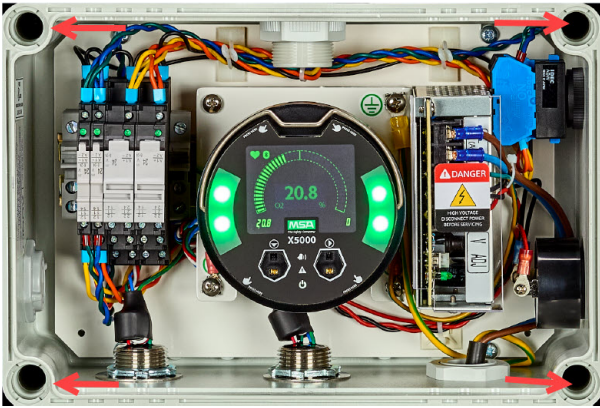

Figure 11 Internal Mounting Holes

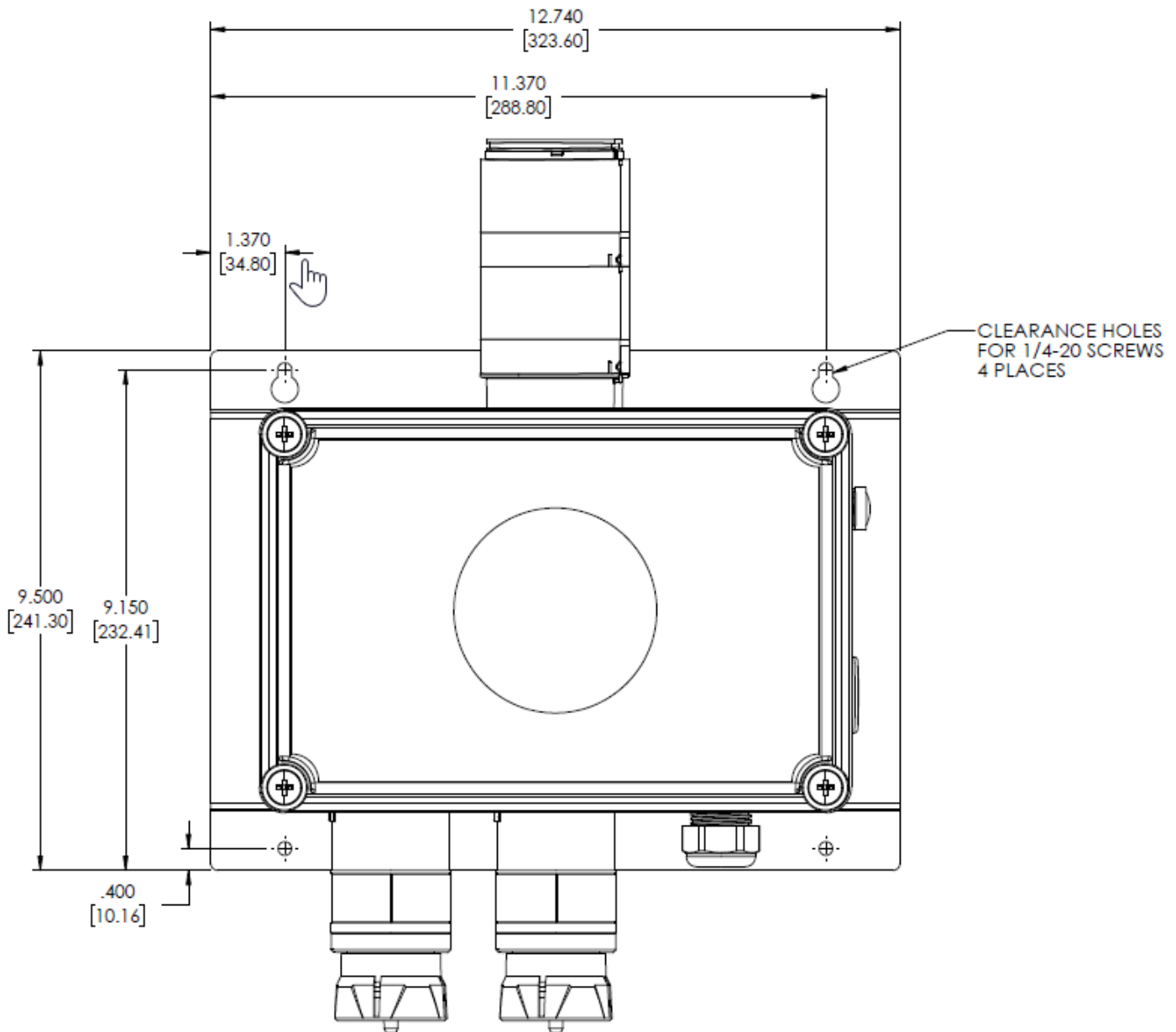

Figure 12 Mounting Bracket (Optional)

### 3.3.7 Installing a Remote Sensor Junction Box

Sensors mounted remotely must use a JP5000 junction box. Only one sensor can be connected to each junction box. The instructions for connecting the sensor to the TG5000 are outlined in [3.3.5 Connecting the Sensor to Transmitter Housing or Remote Junction Box](#). The JB5000 junction box is available in 316 Stainless Steel.

Sensors can be remoted up to 328 ft (100 m) from the transmitter housing, as long as the TG5000 transmitter is mounted within maximum distance from the power supply. See the Ultima X5000 Gas Monitor Manual (P/N 10177361) for wire lengths. The junction box does not have an illuminated display and has two connectors: a single sensor input and an output connecting to the transmitter. A 16 AWG (1.31mm<sup>2</sup>) 4 element cable with a braided shield should be used for the electrical connection between the junction box and the TG5000 transmitter. Specific cable recommendations are Alpha wire 3248 or equivalent.

**NOTE:** The JB5000 junction box must be used for remote XIR PLUS sensors. The use of third party junction boxes may void product warranty.



Figure 13 XP Junction Box

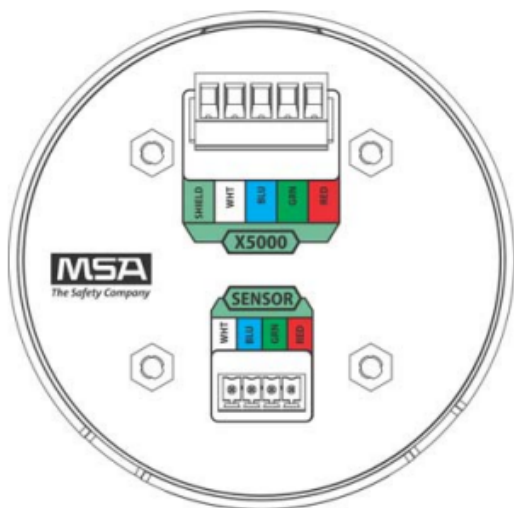

Figure 14 Junction Box Electrical Connections

### 3.3.8 XP Remote Sensor 2" (50.8 mm) Pipe Mount

The integrated mounting tabs on the remote sensor housing can be mounted to a 2" (50,8 mm) pipe using a standard U-bolt. MSA provides U-bolts as an optional accessory (P/N 10179873), however any 2" (50.8 mm) pipe U-bolt rated for the

### 3 Installation

---

weight and dimensions of the housing can be used.

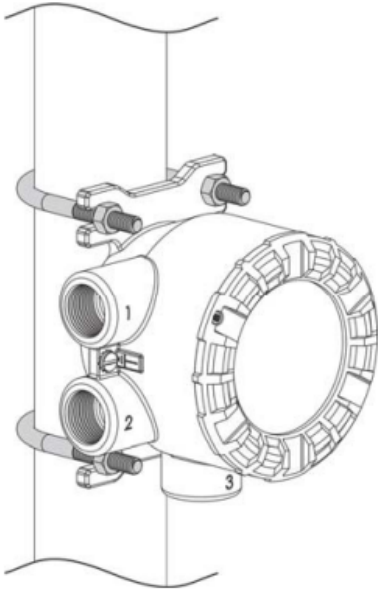

*Figure 15 2" Pipe Mount with U-Bolt*

#### 3.3.9 XP Remote Sensor Adjustable Pipe Mount

A Universal Pipe Mount Kit (P/N 10176946) can be used to mount the remote sensor housing on pipes ranging from 1-6" (20-150 mm) in diameter. Two brackets are mounted over top of the integrated mounting tabs and fitted with an adjustable pipe band (not included).

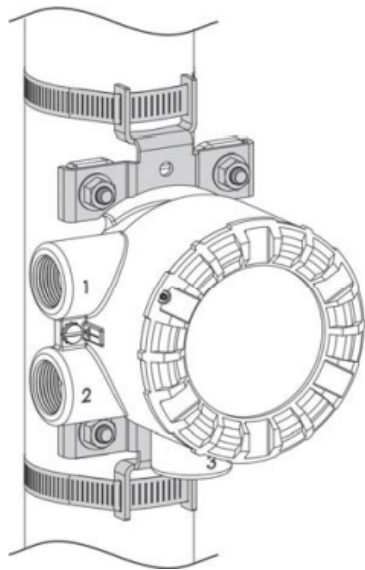

*Figure 16 Adjustable Pipe Mount*

#### 3.3.10 XP Remote Sensor Duct Mount

Duct mount kits are available for monitoring atmosphere inside flat or round ducts. Round duct mount kits are available for small ducts 12-20" (305-508 mm) in diameter (P/N 10179124) and large ducts 20-40" (508-1016 mm) in diameter (P/N 10179321). The flat duct mount (P/N 10176947) is universal for flat ducts.

**⚠ WARNING!**

- Consider the sensor type before choosing a duct mount location. ULTIMA XIR PLUS sensors should be mounted horizontally and all other sensors should be mounted vertically.
- Air flow in the duct must be zero to ensure proper calibration.

**Failure to follow these warnings can result in serious personal injury or death.**

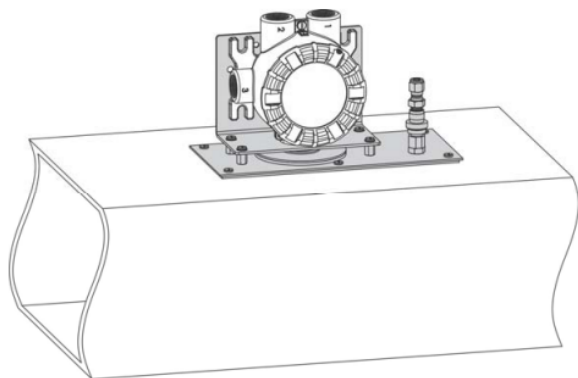

Figure 17 Flat Duct Mount

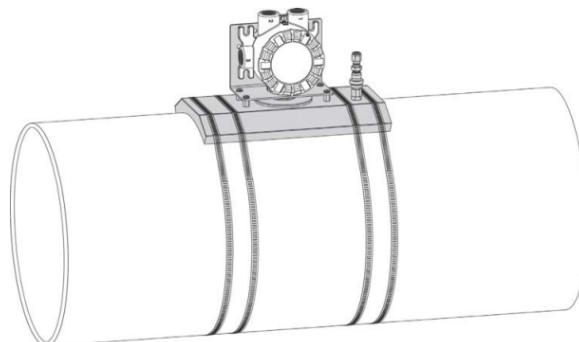
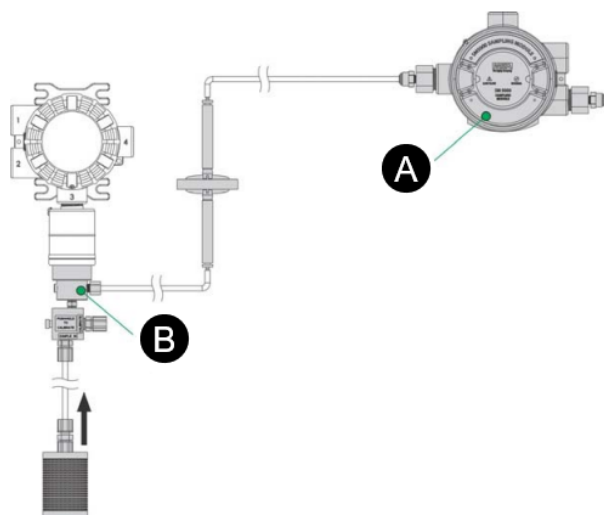

Figure 18 Round Duct Mount

### 3.3.11 Mounting with an SM5000 Sampling Module

An aspirated (P/N 10058101) and a DC pump (P/N 10043264) model are available for use with the TG5000 with either digital or XIR sensors. For more information on mounting requirements and use with SM5000 sampling modules, see the SM5000 operating manual(s).



**A** SM5000 Sampling Module

**B** Digital Sensor Flow Cap

Figure 19 Mounting the SM5000 with Digital Sensor

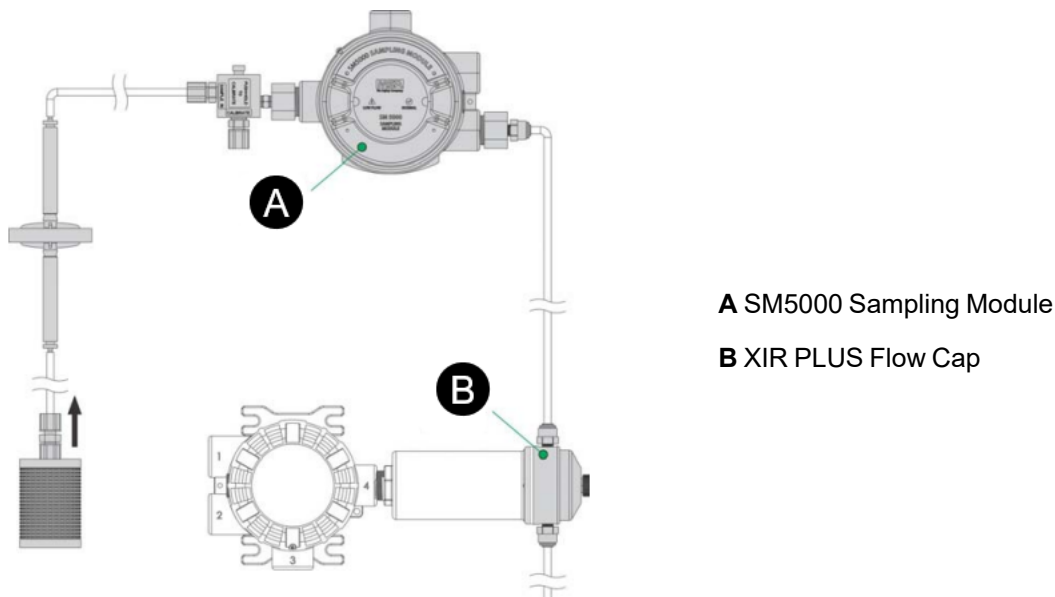

Figure 20 Mounting the SM5000 with XIR PLUS Sensor

If the remote sensor is not easily accessed, it is best practice to install tubing that can be used to apply calibration gas from the device display. Route the tubing to the remote sensor, ensuring that there are no kinks, leaks or other obstructions. Secure this tubing near the monitor.

#### 3.4 Electrical Power Connections

##### 3.4.1 Electrical Warnings - Read Before Connecting Power

### **WARNING!**

- Before wiring the TG5000 transmitter, disconnect the power source supplying the transmitter to ensure no electrical shock could occur.
- Install wiring in accordance with the electrical code of the country in use, the local authority having jurisdiction and these installation instructions, as applicable.
- Do not make any connections to the TG5000 main board or junction box input, output, and relay connections while under power. Making connections under power could lead to electrical shock or ignition of a hazardous atmosphere.
- Ensure that water and dirt are not able to enter the unit via the wire or conduit. If the unit is installed in a location known to be wet or damp, it is good practice to loop or bend the entry into the unit that prevents water incursion.
- The internal grounding terminal located in the base of the transmitter enclosure must be used for equipment grounding. The external grounding terminal is only to be used as a supplemental bonding connection where local authorities permit or require such a connection.
- As part of the product certification, it was verified that optional communication functions of this gas detection instrument while operating at the maximum transaction rate do not adversely affect the gas detection operation and functions of the instrument. The product certification, however, does not include or imply approval of the SafeSwap feature, communications protocol or functions provided by the software of this instrument or of the communications apparatus and software connected to this instrument.
- Follow the warnings below when removing or replacing sensors.
  - Never remove or replace a Sensor Body Assembly or an Ultima XIR PLUS while under power or when explosive hazards are present.
  - Confirm that the area is free of explosive hazards before removing or replacing an XCell Sensor under power.
  - To remove an XCell Sensor, unscrew XCell Sensor three full turns, wait 10 seconds, and then remove the XCell Sensor completely.

**Failure to follow these warnings can result in serious personal injury or death.**

### 3.4.2 Electrical Hardware Requirements

Braided shielded, twisted pair, instrument quality wire or cable should be used to minimize the possibility of noise interference and contact with other voltages. Selection of shielded cable must comply with local requirements.

Conduit, in addition to braided shielded wire, may also be needed in areas where large amounts of electrical noise is expected. All cable shields should be terminated to earth ground at one end only.

The TG5000's power connector terminals can accommodate up to 14 AWG (2.08 mm<sup>2</sup>).

Incoming power and signal cables should be a braided shield cable such as Alpha Wire 3248 or equivalent. The braided shield must be terminated to the instrument housing with a 360 degree connection to earth ground or alternatively, the earth ground at the user's power source location. Incoming power and signal cables should be a braided shield cable such as Alpha Wire 3248 or equivalent.

#### **100-240 VAC Supplied Versions not using optional 120 VAC plug (P/Ns 10236242, 10236243, and 10225300)**

A switch or circuit breaker rated 1.0 A, 250 VAC must be attached to the monitor's AC power leads. This switch must also be located in close proximity to the monitor, and be in easy reach of the operator. This switch should also be clearly marked as the monitor's main AC disconnect device. The circuit breaker or switch must disconnect all current-carrying conductors (i.e., live and neutral).

#### **24 VDC Supplied Versions (P/Ns 10217888, 10217889, and 10217890)**

Connect 24 Volt DC supply to the 'DC+' and 'DC-' connections on the red power connector (Figure 21). Use only Class II rated power supply rated for at least 50 Watts.

### 3.4.3 Instructions for Power and Analog Output

The TG5000 comes wired with AC for the power supply option or wired to terminal blocks (TB1) for the non-power supply option.

The red colored (4-pin) connector interfaces power and analog outputs 1 and 2. The HART interface is a separate, green colored (2-pin) connector.

The green colored (4-pin) connectors interface sensors one and two.

Using shielded cable is recommended. The cable shield should be terminated internal to the instrument enclosure.

#### **TG5000 with power supply option analog output connections:**

1. Remove the TG5000 enclosure cover.
2. Pull on the metal bail, removing electronics, to expose sensor and power connections.
3. Remove the red colored power connector.
4. Use a small, flat head screwdriver to open the analog wire entries on the connector.
5. Connect the analog output wires. Wire locations are marked on the cover plate (Figure 21):
  - a. +DC
  - b. -DC
  - c. mA1 - analog output of sensor 1
  - d. mA2 - analog output of sensor 2

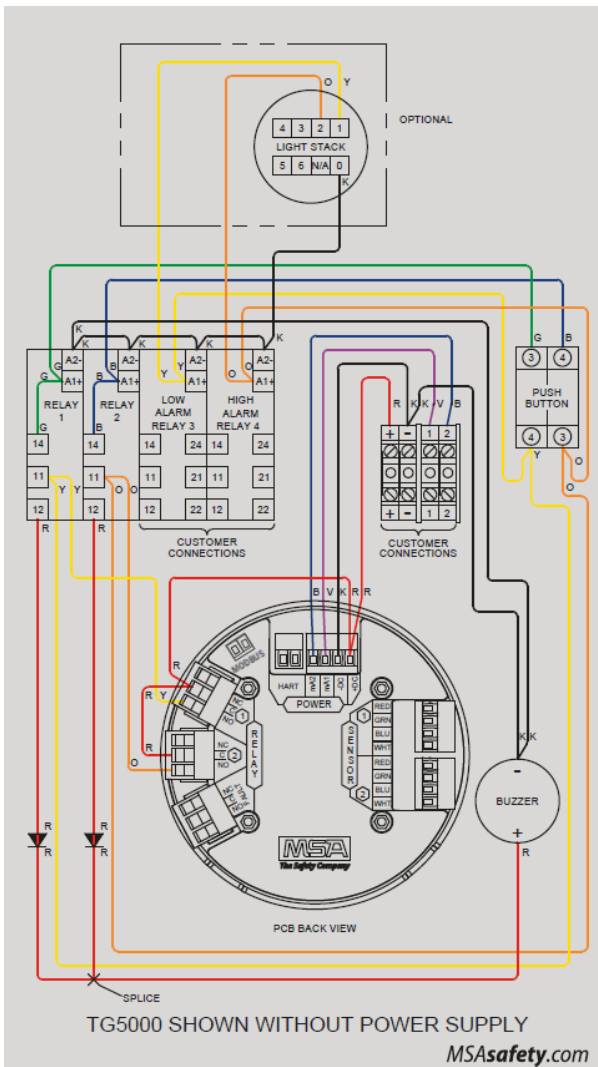

Figure 21 Analog, HART, and Sensor Inputs

6. Tighten screws on connector and tug gently on wires to ensure they are secure.
7. Connect shield of cable to the ground screw.
8. Connect an XCell or XIR PLUS sensor using the green connector. Sensor wires are already connected as shown on the cover plate (Figure 22):
  - a. +DC (RED)
  - b. RS485 Com + (GRN)
  - c. RS485 Com - (BLU)
  - d. -DC (WHT)

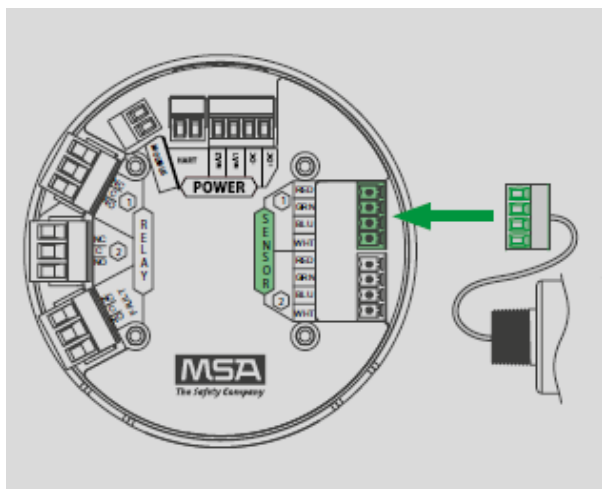

Figure 22 Connecting a Sensor to the Board

**NOTE:** Sensor connectors come pre-wired on the sensor body.

**NOTE:** Leaving exposed wire from the connector can electrically short the system.

**TG5000 without power supply option power and analog output connections:**

1. Remove the TG5000 enclosure cover.
2. Use a small, flat head screwdriver to open the power and analog wire entries on the TB1.
3. Connect the power and analog output connections (Figure 23).
4. Connect ground wire to one of the 2 grounding locations noted with the ground sticker.

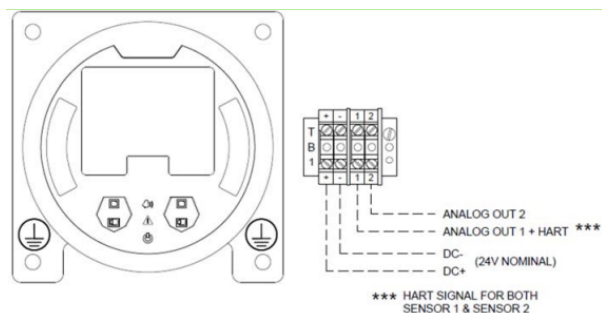

Figure 23 TG5000 without power supply

5. Replace the board stack by aligning the four metal standoffs with the four holes inside the TG5000 housing on the mounting plate. Push firmly on the board stack where indicated (Figure 24).



Figure 24 Highlighted Areas Show Where to Press when Replacing a Board Stack

#### NOTICE

- Ensure that the electronics assembly is fully engaged in the mounting holes. If not fully seated, the touch interface performance can be negatively affected.
- Avoid pressing on the left and right areas where the LEDs are located. Pressing directly on the display will damage the display and will void the warranty.
- Care must be taken to insure the TG5000 label inside overlay surface is free of smudges/dirt and grease. Dirt and grease can interfere with the touch interface of the display.

#### 3.4.4 Relay and Power Connections

##### Relay Board Stack Overview

The TG5000 Relay pack is configured from the two alarm relays on the PCB board stack. Relays 1 and 2 from the PCB board stack operate the integral strobe, sounder and user relay dry contacts. No other connections should be made to the relays 1 and 2 on the PCB board stack (Figure 25). No user connections should be made to the two dedicated horn silence relays on the TG5000 Relay pack terminal strip. Users should connect only connect to the Low Alarm Relay 3 and High Alarm Relay 4. (Figure 26) The third relay on the PCB board stack is a dedicated fault relay (Figure 27). This relay can be used for field connections to monitor the fault status of the TG5000.

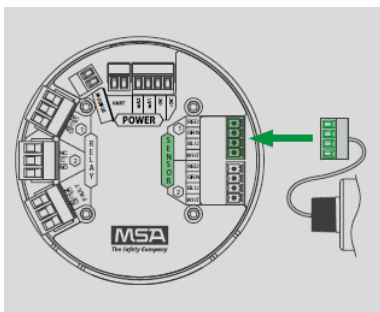
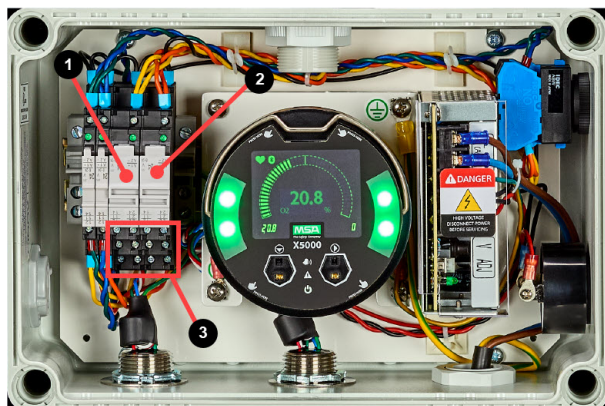

Figure 25 Ultima X5000 PC Board with Relays



- 1 Low Alarm Relay 3
- 2 High Alarm Relay 4
- 3 User Relay Connections

Low Alarm Relay 3  
 14 - NO  
 11 - COM  
 12 - NC

High Alarm Relay 4  
 24 - NO  
 21 - COM  
 22 - NC

Figure 26 User Relay Connections

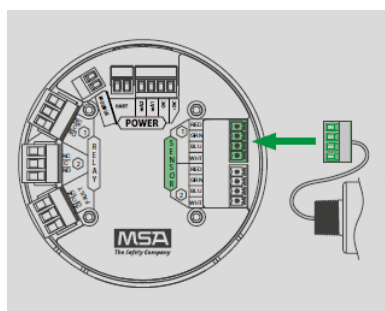

1 Fault Relay

Figure 27 Fault Relay Located on the Ultima X5000 Board Stack

### Relay Specifications

**⚠ WARNING!**

- This relay is labeled for Normally Open (NO) and Normally Closed (NC) de-energized state. The TG5000 default relay mapping mode is Common mode and must not be changed. DO NOT modify relay mapping.
- DO NOT modify relay mapping. Changing the relay mapping will cause the TG5000 relay pack, horn, horn silence button and installed light stack to not work properly and users may not be alerted to presence of gas.

**Failure to follow these warnings can result in serious personal injury or death.**

Table 2 Relay Specifications

Ultima X5000 Relay	SPDT (Single Pole Double Throw)
Fault	Normally Energized
Relay Rating	
125 or 250 VAC (Resistive)	5A
30 VDC (Resistive)	5A
TG5000 Relay Pack	DPDT (Double Pole Double Throw)
Low Alarm, Relay 3	Normally De-Energized
High Alarm, Relay 4	Normally De-Energized
Relay Rating	
250 VAC (Resistive)	6A
30 VDC (Resistive)	1.5A

## 4 Operation

---

If using AC power on the fault relay contacts, the relay wires should not be run within the same conduit or cable tray as the DC power supplied to the TG5000 or the TG5000 junction box connection. A separate wire entry on the device should be used for AC power connected to the relays.

**NOTE:** Exceeding the volt-amp rating of the relay can cause damage to the switching contacts.

### Relay Connections to Inductive Loads

If connecting the relays to motors, fluorescent lighting, or other inductive loads, it is necessary to suppress any sparks or inductive feedback that may occur at the relay contact. These effects may render the unit inoperative.

One way to reduce these effects is to install a Quench arc® (P/N 630413) across the load being switched.

### Fault Relay Wiring and Configurations

The fault relay state in non-fault operating condition is Energized and terminal connections are supplied for Normally Closed and Normally Open.

The energized fault relay setting provides an electrical path for fail-safe relay operation. In the event of any failure, including loss of power, the relay will change to the de-energized state to indicate a fault condition.

The fault relay state cannot be reconfigured.

### Relay Energy State and Terminal Connections

The TG5000 relays 1 and 2 are selected by default as energized state. The X5000 relay energy state should not be changed from default setting

## 3.5 Internal Power Supply

The optional internal power supply is 24 VDC. A 3-meter (9.84 foot) AC cord is included with this option for easy power-up

## 4 Operation

The TG5000 Series transmitter is factory calibrated and shipped with the most common default options to minimize set up effort. Any of the default settings can be changed to meet the user's individual needs via the EZ touch buttons on the display of the TG5000.

### WARNING!

The TG5000 default relay mapping mode is Common mode and must not be changed. Changing the relay mapping will cause the TG5000 relay pack, horn, horn silence button and installed light stack to not work properly and users may not be alerted to presence of gas.

**Failure to follow this warning can result in serious personal injury or death.**

---

## 4.1 Startup

### 4.1.1 Initial Startup

The first time the TG5000 is powered on, the analog output defaults to the Maintenance Mode setting (default 3.5 mA) and the following will appear on the display while the LEDs cycle from GREEN, to RED, to AMBER, then to GREEN: ULTIMA

- X5000 Logo with Software Version No.
- Tachometer countdown
- MSA Logo

XCell oxygen and carbon monoxide (CO) sensors require a 30-minute start-up time before being fully functional. During this time the analog output signal will be at its maintenance (3.5 mA) level while the display indicates the 30-minute countdown. All other XCell sensors have a 2-minute countdown time during which the analog output signal will be at its maintenance (3.5 mA) level. A full calibration is recommended after one hour of a sensor being installed and acclimated to the environmental conditions. See [5 Calibration](#) for calibration details.

### 4.1.2 Sensor Warm Up Times

#### **WARNING!**

For optimal sensor performance, allow sensors 24 hours to acclimate to application conditions before performing an initial calibration.

**Failure to follow this warning can result in serious personal injury or death.**

XIR PLUS: ≤ 5 min  
 H<sub>2</sub>S: ≤ 5 min  
 SO<sub>2</sub>: ≤ 5 min  
 Cl<sub>2</sub>: ≤ 10 min  
 NH<sub>3</sub>: ≤ 5 min  
 Cat Bead: ≤ 5 min  
 CO: 30 min (Table 3)  
 O<sub>2</sub>: 30 min

Carbon Monoxide sensor gas codes 10, 11, 12, and 14 may require initial warm-up periods longer than 30 minutes. If the 30-minute warm up is over, the sensor may show a positive reading that exceeds alarm levels. In the event of a short-term power outage, the warm-up time for carbon monoxide gas codes 10, 11, 12, and 14 will be significantly less. See Table 3 to estimate required warm-up time.

Table 3 Warm-Up Times CO

Reading Level	<10ppm <sup>1</sup>	<1ppm
Time left unpowered	Time to warm-up	
1 minute	<5 minutes	<5 minutes
8 hours	<30 minutes	<30 minutes
5 days	<30 minutes	2-4 hours
1 month	<2 hours	6-10 hours

<sup>1</sup> The minimum alarm level of all three CO sensors is 10ppm. Below this level would not cause an alarm on the device.

## 4.2 Settings

The TG5000 is a tool free transmitter. The two EZ touch buttons on the face of the display can be used to navigate through the menu structure. The buttons are designed for use with fingers with a “press” and “release” action and work best without gloves.

Table 4 Navigating through the menu structure

Button	Function
left button (↓)	scrolling through each menu
right button (→)	selecting a particular menu option

### Changing a value

1. Select the relevant option with →.

*The arrow disappears and the first digit to change appears underlined.*

2. Scroll through the numbers with ↓.
3. Use → to move on to the next digit.

*When the arrow reappears, the value changing is finished.*

## 4 Operation

When entering a new value, remember the following to ensure settings are saved:

- Use *SAVE* before exiting or settings will be lost.
- Use *BACK* to go back to previous screen.
- Use *CANCEL* to go back to main settings menu (i.e. BACK).
- Use *HOME* to return to gas reading display.

### 4.2.1 Instrument Settings

The following settings are saved to the device memory and will not change if the sensor type is changed.

1. Scroll to *Settings*.
2. Select *Instrument*.
3. Select to enter the menu.

Table 5 Default Device Settings

Setting	Default	Menu 1 Options	Menu 2 Options
Analog Settings (see Table 6 )	Custom 1 (see Table 6 )	3.5 mA with HART 1.25mA with HART Custom 1 Custom 2	Custom Settings Calibration Cleaning Mode <sup>1</sup> Fault Maintenance
Bluetooth	Enabled	Bluetooth Status Reset All	Enable Disable Reset All
Min/Max/Avg	1 hr	Interval (1h, 8hr, 24h) Start Hour (0-23 hr)	
Swap Display	Enabled	Enable Disable	
Set Date	UTC-5 (Factory Date and Time)	Year (2000-2999) Month (Jan-Dec) Day (0-31) Time (0:00-23:59)	
Password	Disabled	0000-9999 incr. 0001	
Controller Data Reset	N/A	Controller Data Reset	
Display Units	Sensor Dependent (see Table 14)	PPM mg/m3 µMol %Vol	
Tag #	Blank	Only configurable via HART and Bluetooth	
Reset Main Unit	N/A	Reset Main Unit	

<sup>1</sup>Cleaning mode not available.

### Setup Relay State for Energized or De-Energized

The relay configuration from the factory should not be altered as it will cause undesirable operation of the local strobes, horn and push button.

## Analog Output Settings for Fault Conditions

Analog outputs can be set to 3.5 mA and 1.25 mA with HART, or to custom output values as listed in Tab. 13. Output settings for oxygen sensors are not configurable. The Maintenance analog output is used during start up, Reset Main Unit, and Controller Data Reset.

To change Analog outputs settings:

1. Scroll to *Settings*.
2. Select *Instruments*.
3. Scroll and Select *Analog Settings*.
4. Select *3.5*, *1.25*, *Custom 1* or *Custom 2*.
5. Select *Save*.
6. (Only Custom) Select *Fault*, *Calibration*, or *Maintenance*.
7. (Only Custom) Enter desired output levels (options in [Table 6](#)).
8. (Only Custom) Select *Save*.
9. (Only Custom) Repeat for remaining outputs.
10. Select *Save*.

Table 6 Analog Output Settings Options

Output Setting (mA)	3.5 mA	1.25 mA	Custom 1 Default	Custom 2 Default	AO Range Options
Fault	3.5 <sup>2</sup>	1.25 <sup>2</sup>	2.0	2.0	Range: 0.000-3.750 Increment: 0.025
Calibration (excl. O <sub>2</sub> )	3.5 <sup>2</sup>	1.5 <sup>2</sup>	3.0	3.0	Range: 0.000-3.750 Increment: 0.025
Cleaning Mode (NOT ENABLED)	3.5 <sup>2</sup>	2.0 <sup>2</sup>	2.5	2.5	Range: 0.000-3.750 Increment: 0.025
Maintenance	3.5 <sup>2</sup>	3.5 <sup>2</sup>	3.5	3.5	Range: 0.000-3.750 Increment: 0.025
O <sub>2</sub> Calibration	3.5 <sup>2</sup>	1.5 <sup>2</sup>	21.7 <sup>3</sup>	Same as Calibration	Range: 0.000-3.750 Increment: 0.025
Cal Alert	3.5	3.0	3.0	3.0	Range: 0.000-3.750 Increment: 0.025
Zero Reading	4.04 <sup>2</sup>				
Over Range	21.7 <sup>2</sup>				

<sup>1</sup> Default factory setting

<sup>2</sup> Not configurable

<sup>3</sup> For an O<sub>2</sub> sensor, 21.7 mA is the default Custom 1 setting and is not configurable.

### Calibration Alert

Sensors with TruCal technology actively monitor sense and adjust sensitivity without any manual intervention. When equipped with Diffusion Supervision, TruCal will also monitor the sensor inlet for obstructions while Diffusion Supervision is enabled. These sensors do not need to be calibrated on a static maintenance cycle. When a manual calibration is recommended, the sensor will detect this and slow flash either the left green LED or right green LED indicating that calibration is recommended for sensor 1 or sensor 2 respectively. Users can also enable Calibration Alert so that an analog output signal is sent to the control room when a calibration is recommended.

Whether or not the calibration alert is enabled, if gas is detected by the sensor, the Ultima X5000's analog output and display will follow the gas reading.

### To Enable Calibration Alert

## 4 Operation

---

1. Scroll to *Settings*.
2. Select *Instrument*.
3. Scroll and select *Cal Alert*.
4. Select *Enable Cal Alert*.
5. Scroll and select *Save*.

### Enable Bluetooth Communications

Every TG5000 ordered with Bluetooth comes with the communications enabled by default. Bluetooth must be enabled for any Bluetooth functions to operate. A compatible Bluetooth host with the X/S Connect app is needed for connection.

To disable Bluetooth:

1. Scroll to *Settings*.
2. Select *Instrument*.
3. Scroll and select *Bluetooth*.
4. Select *Bluetooth Status*.
5. Select *Disable*.
6. Select *Save*.

### Bluetooth Pairing

The instrument memory can store up to 25 mobile devices in its memory. As a visual indication, the green LEDs will toggle and quickly flash when a device is paired. Once paired with an TG5000, the user will be able to connect to the same TG5000 remotely and without needing to enter a pairing code, unless over 25 other devices are paired with the same TG5000 afterwards.

To pair with the TG5000:

1. Download the X/S Connect App from the Google Play Store or the iOS App Store.
2. Open the X/S Connect App.
3. Select *Connect* for the TG5000 that you would like to connect with.
4. (First Time Only) When prompted, tap EZ touch button to display a 6-digit pass code.
5. Enter Pairing Code shown on TG5000 display.

### Bluetooth Security

The Bluetooth connection is encrypted and secured with a unique six-digit pin that must be confirmed on the mobile device and acknowledged on the detector display. Previously paired devices can be erased from the TG5000 to provide additional security and control.

To Reset All device pairings:

1. Scroll to *Settings*.
2. Select *Instrument*.
3. Scroll and select *Bluetooth*.
4. Scroll and select *Reset All*.
5. Select *Continue*.

### **NOTICE**

Reset All will delete all paired device memory. All devices will have to re-initiate pairing at the device.

---

### Bluetooth Tag ID

See [0.1 Status Menu](#) to view Bluetooth Tag ID.

## Min/Max/Average

The minimum, maximum, and average gas readings can be set for a user-defined interval. For example, if the interval is set to 24 and the start hour is set to 6, the Min/Max/Avg values will update every 24-hour period starting at 6 am. The default interval is set to 1h and start hour is 0. The Interval and Start Hour are driven by the Time and Date of the transmitter.

To change Min/Max/Average interval and time:

1. Scroll to *Settings*.
2. Select *Instrument*.
3. Scroll and select *Min/Max/Average*.
4. Select *Set Interval*.
5. Enter Interval (1h, 8h, 24h) and *Save*.
6. Scroll to *Set Start Hour*.
7. Enter Start Hour (0-24h) and *Save*.

**NOTE:** The Min/Max/Average values are only viewable through the X/S connect app or HART.

## Swap Delay

Swap Delay allows the user a brief window to change an XCell sensor without the device going into a fault condition. Once a sensor is disconnected from the transmitter, the user will have 2 minutes to reconnect a sensor. During this time, the device analog output will go to its Maintenance level. If a sensor is reconnected or replaced during the 2-minute window, the new sensor's countdown sequence will begin, and the analog output will remain at the Maintenance level. After the sensor countdown is complete, the analog output will return to reporting a live gas reading. If a sensor is not reconnected after the 2-minute window, the TG5000 will enter a "Sensor Missing" fault condition. All XCell Sensors have SafeSwap and do not need to be disconnected from power while changing sensors. For more details on how to change sensors, see [6.2 Replacing an XCell Sensor](#). Swap Delay is enabled on all TG5000 transmitters by default.

### NOTICE

The transition to maintenance mode during the 2-minute Swap Delay window and sensor countdown will not trigger the Fault Relay. The Fault Relay will only be triggered when the device enters a fault condition.

To enable or disable Swap Delay:

1. Scroll to *Settings*.
2. Select *Instrument*.
3. Scroll and select *Swap Delay*.
4. Select *Enabled* or *Disabled*.
5. Select *Save*.

## Time and Date Setup

Time and date are set at the factory in GMT. When selected, the current date is displayed. Select *Change* to edit date and time. The user must save to move onto the next date setting. The Min/ Max/Average settings are driven by the date and time and should be changed to local time for data accuracy.

To change Time and Date:

1. Scroll to *Settings*.
2. Select *Instrument*.
3. Scroll and select *Set Date*.
4. Scroll and select *Change*.
5. Select *Year* and *Save*.
6. Select *Month* and *Save*.
7. Select *Day* and *Save*.

## 4 Operation

---

8. Set *Time* and *Save*.

**NOTE:** You can also use the X/S connect app to sync time and date with a mobile device.

### Enable Password

Enabling password will require the user to enter the password before entering any of the settings menu. The password entry screen defaults to 0000 and is disabled by default.

When the password is enabled, a lock icon will appear in the top right corner of the display. If the password is lost, call MSA Customer Service at 1-800-672-2222.

To enable the password:

1. Scroll to *Settings*.
2. Select *Instrument*.
3. Scroll and select *Password*.
4. Select *Enable Password*.
5. Scroll and select *Save*.
6. Confirm the Password (password is default 0000 until changed).

### Change Password

A password can be changed whether or not the password is enabled.

If the password is lost, call MSA Customer Service at 1-800-672-2222.

To change the password:

1. Scroll to *Settings*.
2. Select *Instrument*.
3. Scroll and select *Password*.
4. Select *Change Password*.
5. Enter desired password.
6. Select *Save*.
7. Scroll and select *Save* to confirm password.

### Language

The TG5000 main display can be viewed in multiple languages. Available Languages are English, French, Spanish, Portuguese, Italian, Dutch, Russian, Chinese, and German.

The X/S Connect App is only available in English and does not change when the display language on the TG5000 is changed.

To change the display language:

1. Scroll to *Settings*.
2. Select *Instrument*.
3. Scroll and select *Language*.
4. Select English, French, Spanish, Portuguese, Italian, Dutch, Russian, Chinese, or German.
5. Scroll and select *Save*.

### Controller Data Reset

Controller Data Reset will reset all of the settings in the main PCBA to their factory defaults and cycle power to the unit.

To reset data to factory default values:

1. Scroll to *Settings*.

2. Select *Instrument*.
3. Scroll and select *Controller Data Reset*.
4. Select *Continue*.

The unit will reboot, and the analog output will default to the values entered for Maintenance.

### Display Units

The default display units are dependent on the sensor type. See Tab 14 for default sensor units. Only % LEL is available for combustible sensors. Only % is available for oxygen sensors.

To change display units:

1. Scroll to *Settings*.
2. Select *Instrument*.
3. Scroll and select *Units*.
4. Select *PPM, mg/m3 or  $\mu$ Mol*.
5. Scroll and select *Save*.

### Tag Number

Displays current tag. Default is blank. Below are the valid characters one can enter to identify their unit. Entering the tag is only available via the X/S Connect App and HART. When changed, this will be the name used by the transmitter for advertising Bluetooth signal.

Table 7 Valid Characters

@	A	B	C	D	E	F	G	H	I	J	K	L	M	N	O
P	Q	R	S	T	U	V	W	X	Y	Z	[	\	]	^	-
SP	!	"	#	\$	%	&	'	(	)	*	+	,	-	.	/
0	1	2	3	4	5	6	7	8	9	:	;	<	=	>	?

### Reset Main Unit

Reset Main Unit will cycle power on the instrument, without changing any of the settings.

To reset the main unit:

1. Scroll to *Settings*.
2. Select *Instrument*.
3. Scroll and select *Reset Unit*.
4. Select *Continue*.

The unit will reboot, and the AO will default to the values entered for Maintenance.

### 4.2.2 Sensor Settings

The following settings are saved to the TG5000 so that if the sensor is replaced with the same sensor type (gas and range), the settings will remain the same. If a different sensor type and range is used to replace the previous sensor, the new sensor's default settings will upload to the device.

To change sensor settings

1. Scroll to *Settings* and select it.
2. Select *Sensor*.
3. Select an option to enter the menu.

### Alarm Set Points

## 4 Operation

---

There are two configurable alarm set points for each sensor. Alarm set point maxima are limited to the full-scale range of the sensor. Alarm minima are listed in Tab. 14.

To change alarm set points:

1. Scroll to *Settings* and select it.
2. Select *Sensor*.
3. Select *Alarm Setup*.
4. Select *Alarm Set Points*.
5. Enter desired alarm set point (this will be limited by sensor range).
6. Scroll and select *Save*.

### Alarm Actions

Relays can be triggered by an alarm threshold as gas readings increase or decrease. Most applications require increasing alarm thresholds, except for Oxygen monitoring, which is most often a decreasing alarm.

Relays can also be triggered such that the relays are latched in the alarm state until a user acknowledges the alarm by placing one finger over each of the EZ touch buttons and holding for 1 second before releasing. If the alarm relay state is chosen to be Non-Latching, the relay will reset once the alarm condition (gas value) returns to a value outside of the alarming condition.

A user can also disable alarms in the Alarm Actions menu.

To change alarm actions:

1. Scroll to *Settings* and select it.
2. Select *Sensor*.
3. Select *Alarm Setup*.
4. Scroll and select *Alarm Actions*
5. Select *Sensor 1* or *Sensor 2*.
6. Select *Alarm 1 Actions* or *Alarm 2 Actions*.
7. Select *Disabled*, *Increasing/Non-Latching*, *Increasing/Latching*, *Decreasing/Non-Latching*, or *Decreasing/Latching*
8. Scroll and select *Save*.

### Span Value

The span value is used to set the calibration point. The default span values are approximately half of the total range of the sensor as purchased (see Tab. 14). If the range is changed, the span value should also be changed to increase accuracy over the full-scale range.

Before changing the span value, the user should ensure that the appropriate concentration of calibration gas is available. The concentration of the calibration gas should match the span value, except if using propane to calibrate a combustible sensor to a different gas cross reference value.

To change the span value:

1. Scroll to *Settings* and select it.
2. Select *Sensor*.
3. Select *Span Value*.
4. Select *Alarm Set Points*.
5. Current Span Value is displayed.
6. Enter desired span value.
7. Scroll and select *Save*.

---

**NOTE:** Default and range of available span values depends on the sensor type. See [4.2.2](#) for default and range of span values.

### Sensor Range

All XCell sensors have adjustable sensor ranges. The sensor range cannot be set below the current alarm set points. The user may need to first lower alarm set points and/or span value in order to adjust sensor range to desired level. The user should also consider adjusting the span value to accommodate the changed sensor range so that the span is in the center of the range.

To change the sensor range:

1. Scroll to *Settings* and select it.
2. Select *Sensor*.
3. Scroll and select *Sensor Range*.
4. Current Sensor Range is displayed.
5. Enter desired sensor range.
6. Scroll and select *Save*.

**NOTE:** Changing the sensor range will change the analog output values for alarm levels.

Table 8 Default Sensor Settings

Gas (Code)	Thread Type <sup>4</sup>	TruCal	Range Default	Display Resolution <sup>3</sup>	Unit Default	Alarm 1 Default	Alarm 1 Default AO (mA)	Alarm 2 Default	Alarm 2 Default AO (mA)	Alarm Action Default	Span Value Default	Alarm Min	Alarm Max	Range Min	Range Max	Span Value Min	Span Value Max
Ammonia (40)	Coarse	○	0-100 PPM	1	PPM	10	5.6	20	7.2	Increasing Non-Latch	25	3	100	0-25	0-100	25	FS <sup>1</sup>
Ammonia (41)	Coarse	○	0-1000 PPM	10	PPM	100	5.6	200	7.2	Increasing Non-Latch	300	100	1000	290	1000	290	FS <sup>1</sup>
Carbon Monoxide (10)	Fine	◐	0-100	1	PPM	15	6.4	30	8.8	Increasing Non-Latch	60	15	1000	0-10	0-1000	5	FS <sup>1</sup>
Carbon Monoxide (11)	Fine	◑	0-500	1	PPM	50	5.6	150	8.8	Increasing Non-Latch	300	15	1000	0-10	0-1000	5	FS <sup>1</sup>
Carbon Monoxide (12)	Fine	◒	0-1000	1	PPM	100	5.6	300	8.8	Increasing Non-Latch	400	15	1000	0-10	0-1000	5	FS <sup>1</sup>
Carbon Monoxide H <sub>2</sub> Resistant (14)	Fine	◑	0-100	1	PPM	15	6.4	30	8.8	Increasing Non-Latch	60	15	1000	0-10	0-1000	5	FS <sup>1</sup>
Carbon Monoxide (36)	Fine	◓	0-100	1	PPM	15	6.4	30	8.8	Increasing Non-Latch	60	15	1000	0-10	0-1000	5	FS <sup>1</sup>
Carbon Monoxide (37)	Fine	◔	0-500	1	PPM	50	5.6	150	8.8	Increasing Non-Latch	300	15	1000	0-10	0-1000	5	FS <sup>1</sup>
Carbon Monoxide (38)	Fine	◕	0-1000	1	PPM	100	5.6	300	8.8	Increasing Non-Latch	400	15	1000	0-10	0-1000	5	FS <sup>1</sup>
Carbon Monoxide (39)	Fine	◖	0-100	1	PPM	15	6.4	30	8.8	Increasing Non-Latch	60	15	1000	0-10	0-1000	5	FS <sup>1</sup>
Catalytic Bead 5% Methane (60)	Fine	○	0-100	1	% LEL	10	5.6	30	8.8	Increasing Non-Latch	50	5	60	0-20 <sup>2</sup>	0-100	10	100
Catalytic Bead 2.1% Propane (61)	Fine	○	0-100	1	% LEL	10	5.6	30	8.8	Increasing Non-Latch	29	5	60	0-20 <sup>2</sup>	0-100	10	100
Catalytic Bead 1.05% Heptane (62)	Fine	○	0-100	1	% LEL	10	5.6	30	8.8	Increasing Non-Latch	45	5	60	0-20 <sup>2</sup>	0-100	10	100
Catalytic Bead 0.8% Nonane (63)	Fine	○	0-100	1	% LEL	10	5.6	30	8.8	Increasing Non-Latch	61	5	60	0-20 <sup>2</sup>	0-100	10	100
Catalytic Bead 4% Hydrogen (64)	Fine	○	0-100	1	% LEL	10	5.6	30	8.8	Increasing Non-Latch	20	5	60	0-20 <sup>2</sup>	0-100	10	100
Catalytic Bead 4.4% Methane (65)	Fine	○	0-100	1	% LEL	10	5.6	30	8.8	Increasing Non-Latch	57	5	60	0-20 <sup>2</sup>	0-100	10	100
Catalytic Bead 1.7% Propane (66)	Fine	○	0-100	1	% LEL	10	5.6	30	8.8	Increasing Non-Latch	35	5	60	0-20 <sup>2</sup>	0-100	10	100

Gas (Code)	Thread Type <sup>4</sup>	TruCal	Range Default	Display Resolution <sup>3</sup>	Unit Default	Alarm 1 Default	Alarm 1 Default AO (mA)	Alarm 2 Default	Alarm 2 Default AO (mA)	Alarm Action Default	Span Value Default	Alarm Min	Alarm Max	Range Min	Range Max	Span Value Min	Span Value Max
Catalytic Bead 0.85% Heptane (67)	Fine	○	0-100	1	% LEL	10	5.6	30	8.8	Increasing Non-Latch	56	5	60	0-20 <sup>2</sup>	0-100	10	100
Catalytic Bead 0.7% Nonane (68)	Fine	○	0-100	1	% LEL	10	5.6	30	8.8	Increasing Non-Latch	70	5	60	0-20 <sup>2</sup>	0-100	10	100
Chlorine (30)	Coarse	○	0-5	0.1	PPM	0.5	5.6	1.0	7.2	Increasing Non-Latch	2.0	0.3	5.0	0-1.0	0-5.0	0.1	FS <sup>1</sup>
Chlorine (31)	Coarse	○	0-10	0.1	PPM	0.5	4.8	1.0	5.6	Increasing Non-Latch	2.0	0.3	10.0	0-1.0	0-10.0	0.1	FS <sup>1</sup>
Chlorine (32)	Coarse	○	0-20	0.1	PPM	2.0	5.6	4.0	7.2	Increasing Non-Latch	10.0	0.6	20.0	0-1.0	0-20.0	0.1	FS <sup>1</sup>
Hydrogen (70)	Fine	○	0-1000 PPM	10	PPM	50	4.8	100	5.6	Increasing Non-Latch	500	30	1000	250	0-1000	250	FS <sup>1</sup>
Hydrogen Chloride (74)	Coarse	○	0-10 PPM	1	PPM	5	5.6	10	7.2	Increasing Non-Latch	10	4	50	0-25	0-50	5	10
Hydrogen Cyanide (75)	Fine	○	0-50 PPM	1	PPM	5	5.6	10	7.2	Increasing Non-Latch	10	3	50	0-6	0-50	6	FS <sup>1</sup>
Hydrogen Flouride (76)	Coarse	No	0-10 PPM	0.1	PPM	1	5.6	2	7.2	Increasing Non-Latch	6	0.5	10	0-0.5	0-10	0.5	FS <sup>1</sup>
Hydrogen Sulfide (23)	Fine	○	0-500 PPM	1	PPM	50	5.6	100	7.2	Increasing Non-Latch	250	1	500	20	0-500	20	FS <sup>1</sup>
Hydrogen Sulfide (24, 77)	Fine	◐	0-20 PPM	0.1	PPM	6	4.8	12	6.4	Increasing Non-Latch	10	1	19	10	20	5	FS <sup>1</sup>
Hydrogen Sulfide (25, 78)	Fine	◑	0-50 PPM	0.1	PPM	15	8.8	30	8.8	Increasing Non-Latch	25	3	48	10	50	5	FS <sup>1</sup>
Hydrogen Sulfide (26, 79)	Fine	◒	0-100 PPM	0.1	PPM	30	8.8	60	8.8	Increasing Non-Latch	50	5	95	10	100	5	FS <sup>1</sup>
Hydrogen Sulfide (42, 80)	Fine	◓	0-20 PPM	0.1	PPM	6	8.8	12	13.6	Increasing Non-Latch	10	1	19	10	20	5	FS <sup>1</sup>
Hydrogen Sulfide (43, 81)	Fine	◔	0-50 PPM	0.1	PPM	15	8.8	30	13.6	Increasing Non-Latch	25	3	48	10	50	5	FS <sup>1</sup>
Hydrogen Sulfide (44, 82)	Fine	◕	0-100 PPM	0.1	PPM	30	8.8	60	13.6	Increasing Non-Latch	50	5	95	10	100	5	FS <sup>1</sup>
Hydrogen Sulfide (20, 83)	Fine	◖	0-10.0 PPM	0.1	PPM	1.0	5.6	3.0	8.8	Increasing Non-Latch	5.0	1.0	100	0-10	0-100	5	FS <sup>1</sup>
Hydrogen Sulfide (21, 84)	Fine	◗	0-50.0 PPM	0.1	PPM	5.0	5.6	15.0	8.8	Increasing Non-Latch	40.0	1.0	100	0-10	0-100	5	FS <sup>1</sup>
Hydrogen Sulfide (22, 85)	Fine	◘	0-100 PPM	0.1	PPM	10.0	5.6	30.0	8.8	Increasing Non-Latch	40.0	1.0	100	0-10	0-100	5	FS <sup>1</sup>
Hydrogen Sulfide (27, 86)	Fine	◙	0-10.0 PPM	0.1	PPM	1.0	5.6	3.0	8.8	Increasing Non-Latch	5.0	1.0	100	0-10	0-100	5	FS <sup>1</sup>
Hydrogen	Fine	◚	0-50.0 PPM	0.1	PPM	5.0	5.6	15.0	8.8	Increasing	40.0	1.0	100	0-10	0-100	5	FS <sup>1</sup>

Gas (Code)	Thread Type <sup>4</sup>	TruCal	Range Default	Display Resolution <sup>3</sup>	Unit Default	Alarm 1 Default	Alarm 1 Default AO (mA)	Alarm 2 Default	Alarm 2 Default AO (mA)	Alarm Action Default	Span Value Default	Alarm Min	Alarm Max	Range Min	Range Max	Span Value Min	Span Value Max
Sulfide (28, 87)										Non-Latch							
Hydrogen Sulfide (29, 88)	Fine	●	0-100 PPM	0.1	PPM	10.0	5.6	30.0	8.8	Increasing Non-Latch	40.0	1.0	100	0-10	0-100	5	FS <sup>1</sup>
Nitrogen Dioxide (73)	Coarse	○	0-10 PPM	0.1	PPM	1	5.6	2	7.2	Increasing Non-Latch	5	0.5	10	0-1.5	0-10	1.5	FS <sup>1</sup>
Oxygen FM(15)	Fine	○	0-25%	0.1	%	19.5	16.48	18.0	15.5	Decreasing Non-Latch	20.8	17	24	5-25	15		
Oxygen (16)	Fine	○	0-25%	0.1	%	19.5	16.48	18.0	15.5	Decreasing Non-Latch	20.8	5.0	25.0	5.0-25	5.0-25	15	25
Low Oxygen (17)	Fine	○	0-25%	0.1	%	1	4.64	2	5.28	Increasing Non-Latch	20.8	0.2	25	0-2	0-25	20.8 (Room Air)	FS <sup>1</sup>
Sulfur Dioxide (50)	Coarse	○	0-25 PPM	0.1	PPM	2.0	5.28	5.0	7.2	Increasing Non-Latch	10	0.4	25	0-5.0	0-25	2.5	25
Sulfur Dioxide (51)	Coarse	○	0-100 PPM	0.1	PPM	10	5.6	20	5.28	Increasing Non-Latch	10	2	100	0-10	0-100	7	FS <sup>1</sup>

<sup>1</sup> FS = Full Scale Range

<sup>2</sup> The Range Max value on catalytic bead cannot be set below 20%

<sup>3</sup> Display resolution is not a configurable option

<sup>4</sup> Class I Division 2 / Zone 2 Only sensors do not have a flame arrestor (aka FRIT). Course threads on the sensor assembly and sensor body are used to prevent a customer from installing into a Class I Division 1/Zone 1 sensor body.

○ Tru Cal not available

● Adaptive Environmental Compensation (AEC) Equipped

● AEC and Diffusion Supervision Equipped

Table 9 Default Sensor Settings - XIR PLUS Sensors

Gas (Codes)	Range Default	Display Resolution	Unit Default	Alarm 1 Default	Alarm 1 Default AO (mA)	Alarm 2 Default	Alarm 2 Default AO (mA)	Alarm Action Default	Span Value Default	Alarm Min.	Alarm Max	Range Min.	Range Max.	Span Value Min.	Span Value Max.
XIR PLUS 5% Methane (AA)	0-100	1	%LEL	10	5.6	20	7.2	Increasing Non-Latch	50	10	60	0-20	0-100	1	100
XIR PLUS 4.4% Methane (AC)	0-100	1	%LEL	10	5.6	20	7.2	Increasing Non-Latch	57	10	60	0-20	0-100	1	100
XIR PLUS 2.1% Propane (AB)	0-100	1	%LEL	10	5.6	20	7.2	Increasing Non-Latch	29	10	60	0-20	0-100	1	100
XIR PLUS 1.7% Propane (AD)	0-100	1	%LEL	10	5.6	20	7.2	Increasing Non-Latch	35	10	60	0-20	0-100	1	100
XIR Plus 0-2.00% CO <sub>2</sub> (AF)	0-2.00	0.02	%	0.20	5.6	.40	7.2	Increasing Non-Latch	1.50	0.20	2.00	0-0.40	0-2.00	0.02	2.00
XIR PLUS 0-5.00% CO <sub>2</sub> (AG)	0-5.00	0.05	%	0.50	5.6	1.00	7.2	Increasing Non-Latch	2.50	0.50	5.00	0-1.00	0-5.00	0.05	5.00

<sup>1</sup> Display Resolution is not a configurable option

### 4.3 Status Menu

The following settings can be viewed through Status Menu without a password, regardless of whether one is enabled.

1. Scroll and select *Status*.
2. Use ↓ to scroll through the list:
  - Tag #
  - Software Version
  - Sensor Type
  - Life and Health
  - Previous Calibration Dates Alarm Setup
  - Alarm 1 Set Point
  - Alarm 1 Actions
  - Alarm 2 Set Point
  - Alarm 2 Actions
  - Relay Setup
  - Mapping Energy State
  - Bluetooth Tag ID
3. Use → to go back to the main menu.

#### 4.3.1 Life and Health - XCell H<sub>2</sub>S and CO Sensors with TruCal Only

The Life and Health information reports the general health of the sensor. XCell sensors with TruCal (Hydrogen Sulfide and Carbon Monoxide) calculate current sensor sensitivity using automated pulse checks. The pulse stimulates the sensor with a response similar to having actual calibration gas applied. The stimulated response is compared to the last calibration and will make adjustments to sensitivity to match the last calibration. When the required adjustment is greater than the accuracy of the algorithm's adjustment, the sensor will call for a calibration.

---

Catalytic bead and Oxygen sensors will show life health status as 'Good' or 'Fair' with the following calculation:



Good condition occurs when the current calibrated span sensitivity is greater than 50% of the way between the initial calibration sensitivity and the end of life span sensitivity. Fair condition occurs when the current calibrated span sensitivity is less than 50% of the way from the initial calibration sensitivity and the end of life span sensitivity.

---

**NOTE:** Using expired calibration gas or the incorrect calibration gas can result in a premature "Fair" status.

## 5 Calibration

Calibration is the process of applying a known quantity of gas to the transmitter so that the transmitter can adjust the precision and accuracy of the measurements made in normal operating mode. This process ensures that gas measurements are as accurate as possible.

## Calibration Warnings - Read before Calibrating

**⚠ WARNING!**

- Use zero gas when zeroing the TG5000 transmitter if there is any possibility of background gas. Otherwise, improper calibration could occur.
- For optimal sensor performance, allow sensor to acclimate to application conditions for 24 hours before performing an initial calibration.
- Perform calibrations 24 hours after initial startup and at a frequency identified in [5.2 Calibration Frequency](#) and [5.3 Calibration Frequency for XCell Sensors with TruCal and Diffusion Supervision \(H2S & CO only\)](#).
- Although TG5000 sensors are factory calibrated, the unit must be calibrated once it is installed in its final environmental destination.

**Failure to follow these warnings can result in serious personal injury or death.**

## 5.1 Calibration Equipment

A gas cylinder with a known concentration of gas appropriate for the range of measurement is needed. Sensors come with preset span gas values appropriate for the measurement range. See Tab. 14 for Default Span Values by Sensor Type. Calibration kits are available from MSA for calibration of the TG5000. The kits come housed in a convenient carrying case and contain all items necessary for a complete and accurate calibration, including a regulator, tubing, and Calibration Caps. See [Table 10](#) to select the appropriate kit for the sensor type. The calibration kit can also be ordered without a gas cylinder.

Table 10 Calibration Kits

Gas Type	Range	Concentration	Cylinder Part Number	P/N with Calibration Kit	Calibration Kit Only (No Cylinder)
Carbon Monoxide	0-100 PPM	60 PPM <sup>1</sup>	710882	710882-KIT1	CALKIT1
	0-500 PPM	300 PPM <sup>1</sup>	10027938	10027938-KIT1	
	0-1000 PPM	400 PPM <sup>1</sup>	10028048	10028048-KIT1	
Hydrogen Sulfide	0-10 PPM	5 PPM <sup>2</sup>	10028084	10028084-KIT1	CALKIT1
	0-50 PPM	40 PPM <sup>2</sup>	10028062	10028062-KIT1	
	0-100 PPM				
Oxygen	0-25%	20.8% <sup>2</sup>	10028028	10028028-KIT1	CALKIT1
Sulfur Dioxide	0-25 PPM	10 PPM <sup>2</sup>	10028070	10028070-KIT2	CALKIT2
Chlorine	0-5 PPM	2 PPM <sup>2</sup>	710331	710331-KIT1	CALKIT1
	0-10 PPM				
	0-20 PPM				
Ammonia	0-100 PPM	25 PPM <sup>2</sup>	10028076	10028076-KIT1	CALKIT1
Combustible (XIR PLUS or Cat. Bead)	0-100% LEL 5% Methane	2.5% Methane (50% LEL) <sup>1</sup>	10028032	10028032-KIT1	CALKIT1
	0-100% LEL 4% Methane	2.5% Methane (57% LEL) <sup>1</sup>			
	0-100% LEL 2.1% Methane	0.6% Propane (29% LEL) <sup>1</sup>	10028034	10028034-KIT1	
	0-100% LEL 1.7% Methane	0.6% Propane (35% LEL) <sup>1</sup>			
XIR PLUS CO <sub>2</sub>	0-2%	1.50% <sup>2</sup>	10179972	10179972-KIT1	CALKIT1
	0-5%	2.50% <sup>2</sup>	10028024	10028024-KIT1	

<sup>1</sup> Balance Air

<sup>2</sup> Balance Nitrogen

Flow Rates:

CALKIT1 = 1 liter/min

CALKIT2 - 0.25 liter/min

## 5.2 Calibration Frequency

The frequency of calibration gas testing depends on the operating time, chemical exposure, and type of sensor. Especially in new installations or applications, it is recommended that the first sensors be calibrated more often to establish the sensor performance in this particular environment.

For this, you typically record the "as found" and "as left" gas values and track the percent adjustment over time. Then, gradually extend calibration intervals until the percent adjustment is greater than the expected accuracy of the sensor.

## 5.3 Calibration Frequency for XCell Sensors with TruCal and Diffusion Supervision (H<sub>2</sub>S & CO only)

Sensors with TruCal technology will adjust sensitivity without any manual intervention or calibration, unless called for by the sensor. If the adjusted sensitivity from TruCal deviates too far from the last gas calibration sensitivity, the sensor will recommend or, in extreme cases, require a calibration. When a calibration is recommended, the transmitter LED status indicators slowly pulse green. Users can also enable a Calibration Alert function that will send a milli-amp signal on the analog output to the control room when a calibration is recommended. When a calibration is required, the status LEDs will flash yellow and the transmitter will go into a Calibration Required Fault. With Diffusion Supervision enabled, the sensors also actively monitor the sensor inlet for obstructions and initiates a fault if the gas diffusion path becomes obstructed.

**With Diffusion Supervision and Calibration Alert enabled, the time between scheduled calibrations can be extended to 24 months.**

If calibration and/or Diffusion Supervision are disabled, follow the calibration frequency recommendations set forth in [5.4 Calibration Frequency for XCell Sensors with TruCal without Diffusion Supervision \(H<sub>2</sub>S & CO only\)](#).

## 5.4 Calibration Frequency for XCell Sensors with TruCal without Diffusion Supervision (H<sub>2</sub>S & CO only)

Sensors with TruCal technology will adjust sensitivity without any manual intervention or calibration, unless called for by the sensor. If the adjusted sensitivity from TruCal deviates too far from the last gas calibration sensitivity, the sensor will recommend or, in extreme cases, require a calibration. When a calibration is recommended, the transmitter LED status indicators slowly pulse green. Users can also enable a Calibration Alert function that will send a milli-amp signal on the analog output to the control room when a calibration is recommended. When a calibration is required, the status LEDs will flash yellow, and the transmitter will go into a Calibration Required Fault. Without Diffusion Supervision, regular calibration of the sensor must still be conducted to confirm the sensor inlet is not obstructed.

Actual TruCal sensor performance will depend on the application, background gas exposure, and environment. To validate XCell sensors with TruCal, it is recommended that users follow their regular calibration cycle and record the "as found" and "as left" values, tracking the percent adjustment over time. Once a baseline is established, the calibration intervals can be extended until the percent adjustment is greater than the expected accuracy of the sensor.

## 5.5 Calibration Types: Zero vs. Span

The TG5000 has two types of calibration: Zero and Span calibration.

Zero Calibration resets the baseline level reading to zero. If the target gas is suspected to be occasionally present, it is best to also use a zero gas cylinder during the zero calibration. If the target gas is not present in the atmosphere, an additional calibration cylinder is not required.

The "Calibrate" option involves first applying a zero gas followed by the span gas. The span gas is a known concentration of gas which adjusts the accuracy and precision of the transmitter to the known value; this is referred to as the "Span Value." See [Figure 28](#).

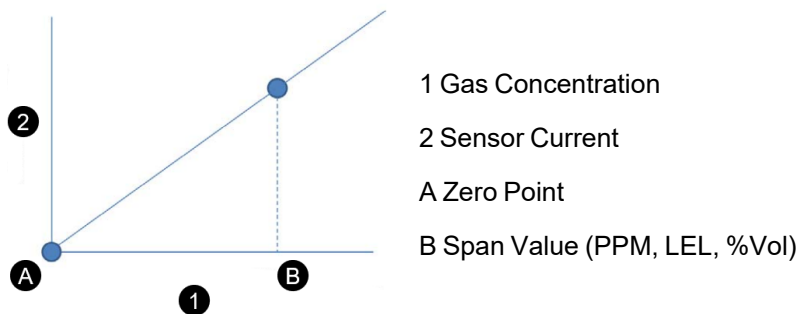

Figure 28 Calibration Curve

The Sensor Span Value in the device menu should be the same as the concentration listed on the calibration gas cylinder, unless an LEL simulant gas is being used.

The XIR PLUS sensor can be calibrated to a wide variety of gas compounds using either 0.1 % propane, 0.6 % propane, or 2.5 % methane, and MSA's gas table. See 9 for a complete list of gas compounds and corresponding tables and span values.

### 5.6 How to Zero Calibrate XCell Sensors

#### NOTICE

If a password is enabled, you will not be able to proceed with the calibration without the password.



To abort, press either button on the touchscreen or mobile application at any time during the zero calibration.

If a calibration cannot be completed, the user can acknowledge the FAIL by placing one finger over each of the EZ touch buttons and holding for 1 second before releasing. The unit will revert to the settings of the last successful calibration.

#### WARNING!

The regulator used with the zero gas cylinder should not be the same as the regulator used for the span gas. The span gas regulator can be contaminated with the target gas over time, and thus raise the detection baseline and make the sensor less sensitive to the target gas.

**Failure to follow this warning can result in serious personal injury or death.**

**NOTE:** If there is no target gas in the atmosphere around the sensor, using a zero gas cylinder is optional.

To Zero calibrate the sensor:

1. Attach the sensor guard to the bottom of the sensor.
2. Place the green calibration cap over the sensor guard inlet so that it is flush with the bottom of the sensor guard and completely covers the sensor guard inlet.
3. Attach the tubing to the plastic stem protruding through the green calibration cap.
4. Screw the regulator onto the top of the zero gas cylinder.

**NOTE:** If a password is enabled, enter it here.

5. Scroll and select calibration.
6. Scroll and select *Zero Calibration*.
7. Once the screen displays *Zero Soaking*, turn on zero gas flow by turning knob on the regulator.
8. Wait while the device displays the countdown of the zero calibration.
9. Once the zero calibration is complete, a Zero PASS or FAIR is displayed.

**NOTE:** If PASS displays, the procedure is complete. User may record the as found and as left values as an indication of the amount of sensor correction performed during the calibration. If FAIL displays, the procedure was unsuccessful.

10. Remove the calibration cap.

**NOTE:** Sensors with TruCal and have Diffusion Supervision enabled can go into Diffusion Supervision Fault if the green calibration cap is left on after completing a zero calibration.

### **WARNING!**

The green calibration cap must be removed from the sensor after a zero calibration. Failure to do so could restrict gas flow to the sensor and result in erroneously low readings.

**Failure to follow this warning can result in serious personal injury or death.**

## 5.7 How to Calibrate XCell Sensors

**NOTE:** See [5.8 How to Calibrate an Oxygen XCell Sensor](#) for calibrating oxygen sensors.

### **NOTICE**

If a password is enabled, the user will not be able to proceed with the calibration without the password.

To abort, press either button on the touchscreen or mobile application before Span Calibration begins.



If a calibration cannot be completed, the user can acknowledge the FAIL by placing one finger over each of the EZ touch buttons and holding for 1 second before releasing. The device will revert to the settings of the last successful calibration.

1. Attach a regulator to the zero gas cylinder (if using) and the calibration cylinder.
2. Attach the sensor guard to the bottom of the sensor.
3. Place the green calibration cap over the sensor guard inlet so that it is flush with the bottom of the sensor guard and completely covers the sensor guard inlet.
4. Attach the tubing to the plastic stem protruding through the green calibration cap.
5. Push the other end of the tubing over the zero cylinder regulator. Ensure the tubing completely covers the gas outlet.
6. Scroll and select *Calibration*.

**NOTE:** If a password is enabled, enter it here.

If the calibration cap cannot be used (such as for a remote sensor application), ambient wind conditions must be minimized during calibration to avoid a calibration with increased sensitivity.

7. Select Sensor #1 or Sensor #2.
8. Once the screen displays *Zero Soaking*, turn on zero gas flow by turning knob on the regulator.
9. Wait while the device displays the countdown of the zero calibration.
10. Once the zero calibration is complete, remove the tubing from the sensor guard inlet.
11. Attach tubing for calibration gas and turn on the regulator
  - a. Display will show *Span in Progress*.
  - b. *Remove Gas* will show when span is complete.

**NOTE:** If PASS displays, the procedure is complete. User may record the as found and as left values as an indication of the amount of sensor correction performed during the calibration. If FAIL displays, the procedure was unsuccessful.

12. Remove the calibration cap.

**NOTE:** Sensors with TruCal and have Diffusion Supervision enabled can go into Diffusion Supervision Fault if the green calibration cap is left on after completing a zero calibration.

### **WARNING!**

The green calibration cap must be removed from the sensor after calibration. Failure to do so could restrict gas flow to the sensor and result in erroneously low readings.

**Failure to follow this warning can result in serious personal injury or death.**

---

### **5.8 How to Calibrate an Oxygen XCell Sensor**

An oxygen span gas cylinder is not needed if the sensor is in an area that maintains ambient air conditions. Follow the same process for XCell sensors as described in [5.6 How to Zero Calibrate XCell Sensors](#). When the display prompts *Apply Span Gas*, simply allow the countdown to occur without applying gas. If the sensor is located in an area of normally low or enriched oxygen, then a 20.8% oxygen sample must be applied.

### **5.9 How to Calibrate an XIR PLUS Sensor**

A full span calibration is not required for the XIR PLUS sensors. Any degradation of the sensor's performance is associated with slight drifts in its zero response. Restoring the sensor's zero is typically sufficient.

The XIR PLUS sensor guard comes attached to the XIR PLUS sensor. The XIR PLUS calibration cap is placed over the sensor guard so that it is completely covered. Line up the cap so that the sensor guard stem protrudes through the calibration cap. Zero or calibration gas tubing is then attached to the sensor guard via the stem.

### **WARNING!**

The green calibration cap must be removed from the XIR PLUS after calibration. Failure to do so could restrict gas flow to the sensor and result in erroneously low readings.

**Failure to follow this warning can result in serious personal injury or death.**

---

### **NOTICE**

If the calibration cap cannot be used (such as for a remote sensor application), ambient wind conditions must be minimized during calibration to avoid a calibration with increased sensitivity.

---

The XIR PLUS sensor can be calibrated to a variety of other target gases. Calibrating to a different calibration gas will align the sensor's accuracy to that gas. Refer to [9 Appendix: Calibration Guide for Additional Gases](#) for calibration settings. Note that the XIR PLUS sensor is a general hydrocarbon sensor and calibrating to another gas will not prevent it from seeing other hydrocarbons in the atmosphere.

### **5.10 XCell Catalytic Bead LOC Over Range**

Catalytic bead sensors require the presence of oxygen in order to sense combustible gas. In the event of very large combustible gas leaks that exceed 100 % LEL, enough oxygen can be displaced so that the sensor's response to gas is no longer proportional to the calibration profile.

The XCell catalytic bead has a locking fail safe mechanism that prevents the false reporting of a safe condition while the % LEL concentration is still above 100 % LEL. When the gas concentration exceeds 100 % LEL, the sensor will go into LOC (Level Over range Condition).

To clear the LOC over range, the user needs to acknowledge and calibrate the sensor. To acknowledge LOC over range, place one finger over each of the EZ touch buttons and hold for 1 second before releasing. This will allow a recalibration of the sensor to clear the LOC condition.

### **WARNING!**

Ensure that the area has been cleared of gas before acknowledging the LOC Over Range and recalibrating the sensor.

**Failure to follow this warning can result in serious personal injury or death.**

---

### 5.11 Calibration Confirmation and As Found / As Left Values

The TG5000 Gas Monitor records the date of the last successful calibration as well as the As Found/As Left values. This date can then be displayed on the OLED display under the Status Menu.

## 6 Maintenance

### WARNING!

- Use only genuine MSA replacement parts when performing any maintenance procedures provided in this manual. Failure to do so may seriously impair sensor and gas monitoring performance, alter flameproof/explosionproof characteristics or void agency approvals.
- Repair or alteration of the TG5000 Gas Monitor, beyond the scope of the maintenance procedures provided in this manual or by anyone other than authorized MSA service personnel, could cause the product to fail to perform as designed and persons who rely on this product for their safety could sustain serious personal injury or loss of life.

**Failure to follow these warnings can result in serious personal injury or death.**

The TG5000 Gas Monitor is constantly performing a self-check. When a problem is found, it displays the appropriate error message. When a critical error is detected within the device, the 4- 20 mA output signal goes to a fault condition.

### 6.1 ULTIMA XIR PLUS Cleaning Procedure

The presence of particulate matter, oil films, liquid water, or the residue from water drops on the two monitor windows can adversely affect its performance. The XIR PLUS Sensor Guard is designed to prevent foreign solids or liquids from reaching the monitor's optical system. Additionally, heating elements are incorporated into the device to prevent water condensation. Under severe conditions, however, some material may collect on these surfaces, and it may be necessary to occasionally check and clean the windows.

While both windows are made of a highly durable material that is not easily scratched, avoid excessive pressure when cleaning them. Clean, cotton-tipped applicators are the most convenient tool to remove material collected on the windows.

- Use a dry applicator or one moistened with distilled water to wipe the window and remove dust.
- Use an additional clean, dry applicator to remove any residual water.
- Use an applicator moistened with isopropyl alcohol to remove heavy deposits of solids, liquids or oil films. Clean the window again with a second applicator moistened with distilled water; then, dry the window with a final applicator.
- Avoid using excessive amounts of water or alcohol in the cleaning procedure and inspect the window to ensure that the entire surface is clean.
- The device will go into a "Low Signal" fault during cleaning with an analog output to 2.0 mA.

To clean the XIR PLUS sensor:

1. Remove the sensor guard.
2. Place an opaque object (piece of paper, cardboard, etc.) between the light source window and the mirror to completely obscure the light path for two to three seconds.

**NOTE:** The TG5000 analog output is in a fault condition while sensor is partially blocked. The display will indicate *Low Signal*.

**NOTE:** While in *Low Signal* fault, the sensor will not respond to the presence of gas.

3. When cleaning is done and the objects are removed from the sensor window, the device returns to normal operation. If water or isopropyl alcohol was used, allow the device to operate for 15 minutes to completely dry before replacing the sensor guard and continuing to monitor for combustible gas.
4. Replace the sensor guard or flow cap.

**NOTE:** When the cleaning process is complete, be sure to remove all objects from the light path. It is recommended to check the sensor's response to zero and calibration gas after cleaning.

**NOTE:** Using other cleaning solutions or not thoroughly removing the isopropyl alcohol with a damp cloth may result in a gas reading from the hydrocarbon bonds of the solvent.

**⚠ WARNING!**

Do not place foreign objects in the sensor's analytical region (except for the [6.1 ULTIMA XIR PLUS Cleaning Procedure](#)); otherwise, the infrared beam can be partially blocked, causing the sensor to generate false readings. All objects must be removed from the sensor's analytical region for it to function properly.

**Failure to follow this warning can result in serious personal injury or death.**

**6.2 Replacing an XCell Sensor**

The only routine maintenance item is the sensor, which has a limited lifetime. The TG5000 sensors with TruCal technology will indicate when the sensor is near end of life through the Status Menu. When the Sensor Life & Health status is "Fair", you have approximately 2 months to replace the sensor before it will no longer function. When a TruCal sensor is no longer capable of sensing it will go into fault and LEDs will flash yellow. It is good practice to obtain a replacement sensing element before the sensing element within your unit becomes inoperative.

There is no need to open the main enclosure. Simply unscrew the digital sensor assembly from the sensor body assembly.

**⚠ WARNING!**

- Do not disassemble the sensor assembly. The sensing element inside may contain hazardous material.
- Handle the sensor carefully; the electrochemical version is a sealed unit which contains a corrosive electrolyte.
- As part of the product certification, it was verified that optional communication functions of this gas detection instrument while operating at the maximum transaction rate do not adversely affect the gas detection operation and functions of the instrument. The product certification, however, does not include or imply approval of the SafeSwap feature, communications protocol or functions provided by the software of this instrument or of the communications apparatus and software connected to this instrument.
- Never remove or replace a Sensor Body Assembly or an Ultima XIR PLUS while under power or when explosive hazards are present.
- Confirm that the area is free of explosive hazards before removing or replacing an XCell Sensor under power.
- To remove an XCell Sensor, unscrew XCell Sensor three full turns, wait 10 seconds, and then remove the XCell Sensor completely.

**Failure to follow these warnings can result in serious personal injury or death.**

Identify the sensor assembly needed via the A-5K-SENS code on the interior sensor label and obtain the appropriate sensor assembly. Screw the replacement XCell sensor onto the Sensor Body Assembly, ensuring that the XCell sensor mates flush against the bottom edge of the Sensor Body Assembly.



Figure 29 Removing the XCell Sensor

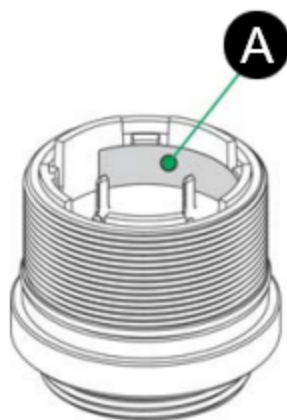

Figure 30 Digital Sensor - Position of Label

A ATO code label

**NOTE:** Alarm set points, span value, full scale limit and alarm direction will not change when replacing a sensor with the same gas and range. Alarm set points, span value, full scale limit and alarm direction will change to the new sensor settings when replacing a sensor with a different gas and/or range.

The TG5000 Gas Monitor is shipped with the Sensor Swap Delay enabled. This means that the 4-20 mA output signal and the fault relay will hold off a fault indication for two minutes before the missing sensor indication is displayed on the device. This setting allows the operator to exchange sensor modules without a fault indication. See Swap Delay in [4.2.1 Instrument Settings](#) for more details.

**NOTE:** It is recommended that all other maintenance be performed at an MSA factory-authorized service center.

### 6.3 Clearing a Blockage

If using a Digital Sensor with Diffusion Supervision, and if the Diffusion Supervision feature has been enabled in the Sensor Settings, the sensor will notify the user if it detects foreign material obstructing the sintered metal frit where gas would normally enter the sensor ([Figure 31](#)). When this condition is detected, the transmitter will go into fault and show “Diffusion Supervision Fault” on the display.

To clear this fault:

1. Inspect and clear the sensor inlet and frit.
2. Inspect and clear any accessories attached to the sensor.
3. Ensure sensor is fully mated to the sensor body assembly.
4. Attempt to recalibrate the sensor.
5. Disable diffusion supervision or replace the sensor.

First, with the sensor still installed, visually inspect the sensor to see if any objects are covering the gas inlet and remove them. Example objects may include tape or the green Calibration Cap.

Next, check to make sure that there is no foreign material stuck to the frit. If any material is found gently remove it while considering any hazards that may arise from such an action, like the accumulation of a static charge and taking the necessary steps to avoid them.

#### **CAUTION!**

- Take care to ensure that the frit is not damaged during the cleaning process.
- DO NOT use water or liquids to try to clean the frit. The frit acts like a sponge and will retain liquids, which will keep the gas path blocked.

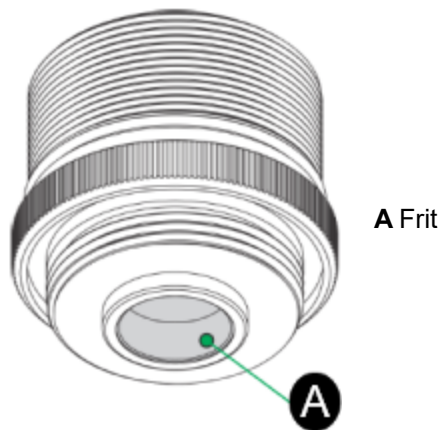

Figure 31 Frit Location

**⚠ WARNING!**

The sensor relies on the frit as a part of its Flameproof/Explosionproof approval. If the frit is damaged while attempting to clean it, immediately remove power from the device. Ensure the area is free of hazardous atmosphere, then follow all steps outlined in this manual to properly replace the sensor.

**Failure to follow this warning can result in serious personal injury or death.**

If no material is visible, the frit may still be blocked by a liquid which has absorbed into the frit.

Once absorbed, liquids are very difficult to remove. For these situations, relying on natural evaporation is recommended. Due to the time it can take for liquids to evaporate sufficiently from the frit, users may want to consider swapping out the affected sensor with one that is known to be clear. Placing absorbent material against the outer surface of the frit can help accelerate this process.

If a sensor is in Diffusion Supervision Fault, the device will still allow the user to attempt to calibrate the sensor. In the rare event that a sensor calibration is successful, but the Diffusion Supervision system continues to detect a blockage in the gas path, the Diffusion Supervision Fault will return in approximately 24 hours. In this scenario, there is likely an environmental factor affecting the Diffusion Supervision detection. Provided the sensor can successfully calibrate, the sensor is still capable of detecting gas. To prevent the Diffusion Supervision Fault from reoccurring, a user can either disable Diffusion Supervision in the Sensor Settings or replace the sensor.

## 6.4 Troubleshooting

Table 11 lists all fault messages, their priority levels, and corrective actions required to resolve them. The faults are listed in alphabetical order. Lower priority messages are output only after the highest priority message is cleared.

Table 11 Troubleshooting

Priority <sup>1</sup>	Display Message	Status LEDs (G/Y/R)	Latch Condition	Description	Resolution
35	"ACT Fault"	ON/ON/OFF	Latch	An out of range adjustment	Replace the sensor.
24	"Beads Off Fault"	ON/ON/OFF	Latch	The combustible sensor beads are OFF.	Acknowledge or cycle power to the sensor. Let the sensor warm-up, then recalibrate the sensor. If this does not resolve the issue, replace the sensor.
23	"Calibration Required"	ON/ON/OFF	Latch	Sensor requires calibration.	Calibrate the sensor(s) attached to the instrument.
25	"Channel Error"	ON/ON/OFF	Latch	Error in the mA output system.	Reset the sensor. Verify sensor configurations (if different from default values). Then recalibrate the sensor. If this does not resolve the issue, replace the sensor.
7	"Configuration Fault"	ON/ON/OFF	Latch	Incorrect configuration was detected.	Typically this is a unit with both sensors disabled and no sensor attached. Attach one sensor to the unit.
16	"Diffusion Supervision Fault"	ON/ON/OFF	Non-Latch	Sensor detected a blockage in the gas path.	Refer to <a href="#">6.3 Clearing a Blockage</a> .
4	"EEPROM Fault"	ON/ON/OFF	Latch	Error with the EEPROM.	Select <i>Reset Main Unit</i> from the Instrument menu. Verify the customer settings.

Priority <sup>1</sup>	Display Message	Status LEDs (G/Y/R)	Latch Condition	Description	Resolution
					Replace the main PCBA.
29	"External Memory Access Error"	ON/ON/OFF	Latch	Error occurred communicating to the EEPROM.	Select <i>Reset Main Unit</i> from the Instrument menu. Verify the customer settings. Replace the main PCBA.
30	"External Memory Checksum Error"	ON/ON/OFF	Latch	EEPROM memory is not valid.	Select Controller Data Reset from Instrument menu. Verify any custom settings and recalibrate the instrument.
3	"Flash Checksum Fault"	ON/ON/OFF	Latch	Something incorrect with the main PCBA's program.	Replace the main PCBA.
8	"General System Error"	ON/ON/OFF	Non-Latch	One of the internal power supplies is out of range.	Adjust the input power supply voltage to within range for the sensor configuration. Replace the main PCBA.
5	"Internal Circuit Fault"	ON/ON/OFF	Latch	Hardware failure on the main PCBA.	Replace the main PCBA.
33	"Lamp Fault"	ON/ON/OFF	Latch	Sensor's lamp is not operating properly (XIR PLUS sensors only).	Replace the sensor.
15	"Life and Health Fault"	ON/ON/OFF	Latch	Sensor is at the end of life.	Recalibrate the sensor to get additional life. If error does not clear after recalibration, replace the sensor.
36	"Low Signal Failure"	ON/ON/OFF	Non-Latch	Sensor output is low.	Clean the optics on the sensor or replace the sensor.
17	"Negative Drift"	ON/ON/OFF	Latch	Sensor is reading downscale.	Recalibrate the sensor.
26	"Negative Supply Fault"	ON/ON/OFF	Non-Latch	Negative power supply is out of range.	Check the input power supply. If this is within range, then replace the sensor.
N/A	"Over Range"	ON/ON/OFF	Non-Latch	An over scale gas ready is present.	Verify the area is clear of gas first, then recalibrate the sensor.
31	"Parameter out of Range"	ON/ON/OFF	Latch	A setting is improperly set in the unit.	Select <i>Control Data Reset</i> from Instrument menu. Verify any customer settings. Then recalibrate the sensor.
2	"RAM Checksum Fault"	ON/ON/OFF	Latch	A bad RAM location detected.	Replace the main PCBA.

## 6 Maintenance

Priority <sup>1</sup>	Display Message	Status LEDs (G/Y/R)	Latch Condition	Description	Resolution
34	"Reference Failure"	ON/ON/OFF	Latch	An out of range measurement.	Replace the sensor.
6	"Relay Fault"	ON/ON/OFF	Latch	A problem with the relays was detected.	Replace the relay options PCBA.
22	"Sensor Configuration Reset"	ON/ON/OFF	Latch	Sensor data-sheet was reset.	Calibrate the sensor.
12	"Sensor Element Error"	N/A	Latch	Sensor is broken.	Replace the sensor.
38	"Sensor End of Life Fault"	ON/ON/OFF	Latch	Sensor is at the end of life	Recalibrate the sensor/ replace the sensor.
27	"Sensor FLASH Error"	ON/ON/OFF	Latch	There is something wrong with the sensors program.	Replace the sensor.
13	"Sensor Heater Fault"	ON/ON/OFF	Latch	Indicates the sensor's heater is not working properly.	Replace the sensor.
25-40	"Sensor Internal Fault"	ON/ON/OFF	Latch	Detected a hardware issue in the sensor.	Replace the sensor.
9	"Sensor Missing"	ON/ON/OFF	Non-Latch	Sensor is no longer detected.	Replace the sensor.
28	"Sensor RAM Error"	ON/ON/OFF	Latch	Bad RAM memory location detected.	Replace the sensor.
10	"Sensor Supply Voltage Fault"	ON/ON/OFF	Non-Latch	Indicates the sensor's input voltage is out of range.	Check the input power supply voltage and check the wiring to the sensor module for damage. If this does not resolve the issue, replace the sensor.
20	"Span Calibration Fault"	ON/ON/OFF	Latch	Indicates the sensor did not pass the span calibration operation.	Acknowledge the fault by pressing and holding both EZ touch buttons at the same time for up to 5 seconds. The unit will revert to the previous calibration so that the unit can continue to detect gas while troubleshooting fault. Causes for this fault include: <ol style="list-style-type: none"> <li>1. Span gas is not applied within the calibration time-out period.</li> <li>2. The incorrect span gas is applied, or the span value is not set correctly in the sensor settings.</li> <li>3. The sensor is at its end of life.</li> </ol>

Priority <sup>1</sup>	Display Message	Status LEDs (G/Y/R)	Latch Condition	Description	Resolution
					Check the span gas concentration and the sensor span value setting to ensure that the correct span gas is being used. Go through the calibration process again after verifying. If fault persists, replace the sensor.
1	"Supply Voltage Fault"	ON/ON/OFF	Non-Latch	The input power supply is out of the operating range. it may be too low or too high.	Check the input power is within range for the sensor configuration.
14	"TEDS CRC-16 Error"	ON/ON/OFF	Latch	Indicates the sensors datasheet is invalid.	Reset the sensor. Verify the sensor settings (if different from default), then recalibrate the sensor.
40	"Unknown Error"	ON/ON/OFF	N/A	Indicates that a sensor is returning an unknown error condition.	Replace the sensor or update the main PCBA software.
19	"Zero Calibration Fault"	ON/ON/OFF	Latch	Indicates the sensor did not pass the zero calibration operation.	<p>Acknowledge the fault to revert to the previous calibration. This fault can be caused by</p> <ol style="list-style-type: none"> <li>1. A bad sensor</li> <li>2. The sensor is trying to zero while span gas is being applied.</li> </ol> <p>Check the zero gas cylinder is correct and within expiration date. If not using zero gas, ensure that there is not a background concentration of the target gas in the atmosphere. Go through the calibration process again after verifying. If fault persists, replace the sensor.</p>
N/A	Full scale value and "LOC" displayed on the lower display areas per each sensor.	ON/ON/OFF	Latch	Indicates a combustible sensor's over range condition was measured.	Acknowledge the sensor, wait for the warmup time period and recalibrate the sensor.
N/A	Gas value is still shown.	Both side green LEDs blinking	N/A	Indicates that calibration is recommended. (TruCal sensors only)	Calibrate the sensors attached to the unit.
11	Parameter	ON/ON/OFF	Latch	Indicates that a setting is	Reset the sensor's

## 7 Ordering Information

Priority <sup>1</sup>	Display Message	Status LEDs (G/Y/R)	Latch Condition	Description	Resolution
	Fault (Sensor)			improperly set in the unit.	datasheets. Verify any customer settings. Then recalibrate the sensor.

<sup>1</sup> Lower numbers have higher priority.

## 7 Ordering Information

### 7.1 Replacement Parts

See [Table 12](#) for replacement parts. For a full list of replacement sensors, see A-5K-SENS (currently not part of the manual). To obtain a replacement sensor, address the order or inquiry to:

Mine Safety Appliances Company  
1000 Cranberry Woods Drive  
Cranberry Township, PA 16066

or call, toll-free, 1-800-672-4678.

Inquiries can also be e-mailed to [customer.service@msasafety.com](mailto:customer.service@msasafety.com).

### WARNING!

- Use only genuine MSA replacement parts when performing any maintenance procedures provided in this manual. Failure to do so may seriously impair sensor and gas monitoring performance, alter flameproof/explosionproof characteristics or void agency approvals. Failure to follow this warning could cause the product to fail to perform as designed and persons who rely on this product for their safety could sustain serious personal injury or loss of life.
- Repair or alteration of the TG5000 Gas Monitor, beyond the scope of the maintenance procedures provided in this manual or by anyone other than authorized MSA service personnel, could cause the product to fail to perform as designed and persons who rely on this product for their safety could sustain serious personal injury or loss of life.

**Failure to follow these warnings can result in serious personal injury or death.**

*Table 12 Replacement Parts*

Type	Description	Part Number
PCBA Assemblies		10190595
Sensor Body		See <a href="#">12 Appendix: System and Sensor Part List</a>
Sensors, All		Refer to A-5K-SENS
Sensor Guard, XCell	Replacement Sensor Guard for XCell Sensors	10184683
Sensor Guard, Ultima XIR PLUS	Replacement Sensor Guard for XIR PLUS Sensors	10184684
Calibration Kit	Calibration Hardware (cylinder not included)	CALKIT1
Calibration Cap, XCell	Calibration Cap, Ultima X5000/S5000, PCKGD	10181450
Calibration Cap, XIR PLUS	Calibration Cap, Ultima XIR PLUS, PCKGD	10181461
Additional Spare Parts	Internal 24 VDC Power Supply	10156728-SP
	Push-button	10217930-SP
	Piezo Buzzer	637123-SP
	Red Strobe	10219221-SP
	Amber Strobe	10219222-SP
	Strobe Base	10217990-SP

For position of labels, see [2.9 Label Overview](#)

## 7.2 Accessories

Type	Description	Part Number
Duct Mount Kit	Rectangular Duct Mount Kit, TG5000	10176947
	Round Duct Mount Kit, Small, TG5000	10179124
	Round Duct Mount Kit, Large, TG5000	10179321
Pipe Mount Kit, Universal	20-150 mm, Pipe Mount, TG5000 / S5000	10176946
Pipe Mount Kit, 2" U-Bolt	2" Pipe Mount Kit, TG5000	10179873
SM5000	Sampling Module, DC Pump Model	10043264
SM5000	Sampling Module, Aspirated Pump	10058101
SM5000	Flow Block Digital	10041866
SM5000	Flow Block XIR	10042600
	Installation kit for integral sensor	10242968
	Mounting Bracket Kit	10242982
	Sunshade Kit (Cannot be used with strobes)	10242985
	Remote JB5000 Junction Box, SS, 3/4" NPT	10213892
	Power Cord 3 Meter, North American 120 VAC plug	10242959
	Power Cord, 3 Meter, European Type F, 220 VAC plug	10250929
	Power Cord, 3 Meter, UK Type G, 220 VAC Plug	10250930

### TG5000 System

Part #	Description
10236242	TG5000, Polycarbonate, 120/240 VAC, No strobe
10236243	TG5000, Polycarbonate, 120/240 VAC, Red Strobe
10225300	TG5000, Polycarbonate, 120/240 VAC, Red+Amber Strobe
10217888	TG5000, Polycarbonate, 24VDC, No strobe
10217889	TG5000, Polycarbonate, 24VDC, Red Strobe
10217890	TG5000, Polycarbonate, 24VDC, Red+Amber Strobe

## 8 Appendix: Specifications

Table 13 TG5000 Specifications

Sensor Options	CO	H <sub>2</sub> S	SO <sub>2</sub>	CL <sub>2</sub>	NO <sub>2</sub>	H <sub>2</sub> S 500 PPM	Hydrogen 1000 PPM	NH <sub>3</sub> - 100 PPM	NH <sub>3</sub> - 1000 PPM	SO <sub>2</sub> - 100 PPM
	Operating Range <sup>2</sup>	-40 °C to +60 °C	-40 °C to +60 °C	-40°C to +60°C	-40°C to +60°C	20°C to +50°C*	-20 °C to +40 °C	-20°C to +50°C*	-30 °C to +50 °C	-30 °C to +50 °C
Storage	-40 °C to +60 °C	-40 °C to +60 °C	-40°C to +60°C	-40°C to +60°C	-40°C to +50°C	-40°C to +50°C	-0°C to +20°C	-20°C to +40°C	-20°C to +40°C	-20°C to +40°C
Zero Drift <sup>1</sup>	< 1% FS per year	< 1% FS per year	≤ 1% FS per month	< 1% FS per month	< 1% FS per month	< 1% FS per month	< 1% FS per month	< 1% FS per month	< 1% FS per month	< 1% FS per month
Span Drift <sup>1</sup>	< 2% FS per year	< 2% FS per year	≤ 2% FS per month	≤ 2% FS per month	≤ 2% FS per month	≤ 2% FS per month	≤ 2% FS per month	≤ 2% FS per month	≤ 2% FS per month	≤ 2% FS per month
Noise <sup>1</sup>	< 2 display units	< 2 display units	< 2 display units	< 2 display units	< 2 display units	< 2 display units	< 2 display units	< 2 display units	< 2 display units	< 2 display units
Repeatability <sup>1</sup>	< ±2%	< ±1%	±1%	±1%	< ±10%	< ±10%	< ±10%	< 1%	< ±15%	< ±15%
Resolution	1 ppm	0.1 ppm	0.1 ppm	0.1 ppm	0.1 ppm	1 ppm	10 ppm	1 ppm	10 ppm	0.5 ppm
T90	< 9 s	< 23 s	< 6s	< 12s	< 60 s	< 60 s	< 185 s	< 60 s	< 300 s	< 30 s
T50					< 30 s	< 20 s	< 40 s	< 20 s	< 20 s	< 10 s
Humidity	5-95%	5-95%	5-95%	5-95%	15-90%	15-90%	15-90%	15-90%	15-90%	15-90%
Expected Sensor Life	5 years	5 years	5 years	5 years	2 years in the air	2 years in the air	2 years in the air	5 years	2 years in the air	2 years in the air
Warranty	3 years	3 years	3 years	3 years	1 year	1 year	1 year	3 years	1 year	1 year
Enabling Technology	XCell - non-consuming	XCell - non-consuming	XCell - non-consuming	XCell - non-consuming	Electro-chemical	Electro-chemical	Electro-chemical	Electro-chemical	Electro-chemical	Electro-chemical
TruCal <sup>3</sup>	Yes	Yes	No	No	No	No	No	No	No	No
SafeSwap	Yes	Yes	Yes	Yes	Yes	Yes	Yes	Yes	Yes	Yes
Remote Mount Distance	100 m	100 m	100 m	100 m	100 m	100 m	100 m	100 m	100 m	100 m
Power: Single Sensor	2.8 W	2.8 W	2.8 W	2.8 W	2.8 W	2.8 W	2.8 W	2.8 W	2.8 W	2.8 W
Power: Dual Sensing	3.6 W	3.6 W	3.6 W	3.6 W	3.6 W	3.6 W	3.6 W	3.6 W	3.6 W	3.6 W
*Extended Range				None	-40°C to +50°C	None	-40°C to +60°C	None		-40°C to +60°C

Sensor Options	Oxygen	Low Oxygen	Combustible Catalytic	XIR PLUS Combustibles	XIR PLUS Carbon Dioxide
	Operating Range <sup>2</sup>	-40 °C to +60 °C	-20 °C to +50 °C	-40°C to +60°C	-40°C to +60°C
Storage	-40 °C to +60 °C	-20 °C to +40 °C	-40°C to +60°C	-40°C to +60°C	-40°C to +60°C
Zero Drift <sup>1</sup>	0.2% Vol per year	< 1% FS per month	< 5% LEL per year	< 2% LEL per year	< 2% FS per year
Span Drift <sup>1</sup>	0.2% Vol per year	< 2% FS per month	< 5% LEL per year	Not Applicable	Not Applicable
Noise <sup>1</sup>	< 2 display units	< 2 display units	1% LEL	1% LEL	0.05%
Repeatability <sup>1</sup>	< ±1%	< ±10%	±1%	±1%	±1%
Resolution	01% Vol	0.10%	1% LEL	1% LEL	<0.05%
T90	< 11 s	< 30 s	< 22 s	< 6 s	< 6 s
Humidity	10-95%	10-90%	5-95%	5-95%	5-95%

Expected Sensor Life	5 years	2 years in air	5 years	10 years	10 years
Warranty	3 years	1 years	3 years	electronics: 5 years IR source bulb: 10 years	
Enabling Technology	XCell - non-consuming	Lead based	XCell - GM cat bead	XIR PLUS	XIR PLUS
TruCal <sup>3</sup>	No	No	No	No	No
SafeSwap	Yes	Yes	Yes	No	No
Remote Mount Distance	100 m	100 m	100 m	100 m	100 m
Power: Single Sensor	2.8 W	2.8 W	4.9 W	6.7 W	6.7 W
Power: Dual Sensing	3.6 W	3.6 W	10.6 W	11.6 W	11.6 W
*Extended Range		-30 °C to +50 °C			

<sup>1</sup> Typical response at room temperature

<sup>2</sup> X5000 transmitter has an operating temperature range of -40°C to +60°C

<sup>3</sup> Adaptive Environmental Compensation (AEC) and Diffusion Supervision (DS) will remain active between -20°C and +60°C.

## 9 Appendix: Calibration Guide for Additional Gases

The ULTIMA XIR PLUS sensor can be calibrated for a wide variety of combustible gas compounds.



This information is only applicable for combustible XIR PLUS sensors and does not apply to CO<sub>2</sub> and acetylene sensors.



The XIR PLUS sensor is only performance approved for Methane and Propane.

To change the XIR PLUS calibration,

1. Scroll and select Settings.
2. Select Sensor.
3. Scroll and select Gas Table.
4. Select the gas table for the target compound.
5. Select Save.
6. Scroll to Span Value and select (should already be in correct menu after saving Gas Table).
7. Enter the span value for the target compound as described in [Table 14](#) .
8. Select Save.
9. Go to the home screen.
10. Run a full calibration (Span and zero) using the calibration gas indicated in [Table 14](#) .

You can now calibrate the XIR PLUS sensor using the calibration gas for the target compound in [Table 14](#) .

**⚠ WARNING!**

You must calibrate the XIR PLUS sensor with the calibration gas indicated in [Table 14](#) for the sensor to be accurate for the target gas.

**Failure to follow this warning can result in serious personal injury or death.**

*Table 14 XIR PLUS Calibration Guide for Additional Gases*

Compound	Vol % for NA LEL	Vol % for EN LEL	Linearity Curve/Table	Cal Gas	NA Span Value	EN Span Value
Acetic Acid	4.0	4.0	3	0.6 % Propane	12%	12%
Acrylic Acid	2.4	2.4	2	0.6 % Propane	10%	10%
Allyl Alcohol	2.5	2.5	1	2.5 % Methane	85%	85%
Amyl Acetate	1.1	1.0	1	2.5 % Methane	80%	88%
t-Amyl Alcohol	1.3	1.4	6	0.6 % Propane	41%	38%
Aromatic 100	0.9	N/A	1	2.5 % Methane	75%	N/A
Butane	1.9	1.4	4	0.6 % Propane	29%	39%
Butanol	1.4	1.4	6	0.6 % Propane	42%	42%
Butene	1.6	1.6	6	0.6 % Propane	57%	57%
Butyl Acetate	1.7	1.2	6	0.6 % Propane	40%	57%
Butyl Acrylate	1.5	1.2	6	0.6 % Propane	45%	56%
Butyl Methacrylate	2.0	1.0	6	0.6 % Propane	33%	66%
Butyraldehyde	1.4	1.7	6	0.6 % Propane	65%	54%
Cumene	0.9	0.8	1	2.5 % Methane	43%	48%
Cyclohexane	1.3	1.0	1	2.5 % Methane	50%	65%
Cyclohexanone	1.1	1.3	6	0.6 % Propane	74%	63%
Cyclopentane	1.5	1.4	7	0.6 % Propane	31%	33%
Cyclopentanone	1.5	1.6	1	2.5 % Methane	60%	56%
Dicyclopentadiene (DCPD)	0.8	0.8	6	0.6 % Propane	55%	55%
Diethylamine	1.8	1.7	2	0.6 % Propane	32%	34%

Compound	Vol % for NA LEL	Vol % for EN LEL	Linearity Curve/Table	Cal Gas	NA Span Value	EN Span Value
Diethyl Ether	1.9	1.7	2	0.6 % Propane	38%	42%
1,1-Difluoroethane (R-152a)	3.7	4.0	2	0.6 % Propane	52%	48%
Diisobutylene	0.8	0.8	2	0.6 % Propane	52%	52%
Diisopropyl Ether	1.4	1.0	6	0.6 % Propane	34%	48%
Dimethylamine	2.8	2.8	2	0.6 % Propane	37%	37%
Dimethylaminopropylamine (DMAPA)	2.3	1.2	2	0.6 % Propane	29%	56%
Dimethyl Ether	3.4	2.7	2	0.6 % Propane	32%	40%
Dimethylethylamine (DMEA)	2.3	N/A	2	0.6 % Propane	22%	N/A
Dimethylisopropylamine (DMIPA)	1.0	1.1	6	0.6 % Propane	47%	43%
1,4-Dioxane	2.0	N/A	4	0.6 % Propane	42%	N/A
1,3-Dioxolane	2.1	2.3	2	0.6 % Propane	35%	32%
Epichlorohydrin	3.8	2.3	6	0.6 % Propane	46%	76%
Ethane	3.0	2.4	3	0.6 % Propane	25%	31%
Ethanol	3.3	3.1	6	0.6 % Propane	35%	37%
Ethyl Acetate	2.0	2.0	6	0.6 % Propane	60%	60%
Ethyl Chloride	3.6	3.6	2	0.6 % Propane	27%	27%
Ethylene Glycol Monomethyl Ether	1.8	1.8	6	0.6 % Propane	60%	60%
Ethylene Oxide	3.0	2.6	6	0.6 % Propane	65%	75%
Gasoline (as Hexane)	1.1	1.0	6	0.6% Propane	41%	45%
Heptane	1.1	0.85	2	0.6% Propane	35%	45%
Hexane	1.1	1.0	6	0.6% Propane	41%	45%
1-Hexene	1.2	1.2	6	0.6% Propane	38%	38%
Isobutane	1.8	1.3	2	0.6% Propane	30%	42%
Isobutyl Alcohol	1.7	1.4	6	0.6% Propane	41%	50%
Isobutyl Isobutyrate (IBIB)	1.0	0.8	1	2.5% Methane	25%	31%
Isobutylene	1.8	1.6	6	0.6% Propane	62%	70%
Isooctane	1.1	0.7	4	0.6% Propane	28%	44%

Compound	Vol % for NA LEL	Vol % for EN LEL	Linearity Curve/Table	Cal Gas	NA Span Value	EN Span Value
Isopropanol	2.0	2.0	6	0.6% Propane	48%	48%
Isopropyl Acetate	1.8	1.7	6	0.6% Propane	57%	60%
Isopropyl Amine	2.0	2.3	6	0.6% Propane	41%	36%
JP-5	0.6	N/A	6	0.6% Propane	41%	N/A
Methanol	6.0	6.0	3	0.6% Propane	23%	23%
Methoxypropylamine	2.3	2.3	6	0.6% Propane	55%	55%
Methyl Acetate	3.1	3.1	5	0.6% Propane	46%	46%
Methyl Acrylate	2.8	1.95	6	0.6% Propane	68%	N/A
Methacrylic Acid	1.6	2.1	2	0.6% Propane	55%	42%
Methyl Amyl Ketone (MAK)	1.1	1.1	6	0.6% Propane	51%	51%
Methyl Cellosolve	1.8	1.8	6	0.6% Propane	60%	60%
Methyl Chloride	8.1	7.6	6	0.6% Propane	48%	51%
Methyl Chloroform (1,1,1-Trichloromethane)	0.1	N/A	6	0.6% Propane	85%	N/A
Methylcyclohexane	1.2	1.0	1	2.5% Methane	33%	40%
Methylene Chloride	13.0	13.0	1	2.5% Methane	68%	68%
Methylene Fluoride (R-32)	12.7	12.7	6	0.6% Propane	13%	13%
Methyl Ethyl Ketone (MEK)	1.4	1.5	1	2.5% Methane	72%	67%
Methyl Formate	4.5	5.0	4	0.6% Propane	29%	26%
Methyl Isobutyl Carbinol (MIBC)	1.0	1.14	2	0.6% Propane	25%	22%
Methyl Isobutyl Ketone (MIBK)	1.2	1.2	6	0.6% Propane	54%	54%
Methyl Methacrylate	1.7	1.7	6	0.6% Propane	72%	72%
Methyl Propyl Ketone (MPK)	1.5	1.5	6	0.6% Propane	54%	54%
Methyl tert-butyl Ether (MTBE)	1.6	1.5	2	0.6% Propane	29%	31%
Monomethyl Amine	4.9	4.2	2	0.6% Propane	33%	39%
Morpholine	1.4	1.4	6	0.6% Propane	59%	59%
Naptha, VM&P	1.2	N/A	6	0.6% Propane	41%	N/A
Nitro Ethane	3.4	3.4	1	2.5% Methane	85%	85%

Compound	Vol % for NA LEL	Vol % for EN LEL	Linearity Curve/Table	Cal Gas	NA Span Value	EN Span Value
Opteon XL 41 (R-454b)	11.3	N/A	3	0.6% Propane	20%	N/A
Pentane	1.5	1.1	5	0.6% Propane	33%	45%
n-Propanol	2.2	2.1	2	0.6% Propane	36%	38%
Propionaldehyde (Propanal)	2.6	2.0	6	0.6% Propane	69%	n.a.
Propyl Acetate	1.7	1.7	6	0.6% Propane	41%	41%
Propyl Bromide	3.8	3.4	2	0.6% Propane	23%	26%
Propyleneimine	1.32	N/A	6	0.6% Propane	72%	N/A
Propylene Glycol Methyl Ether (PGME)	1.8	1.6	6	0.6% Propane	47%	53%
Prop. Glycol Meth. Ether Acetate (PGMA)	1.5	1.3	6	0.6% Propane	67%	77%
Propylene Oxide	2.3	1.9	2	0.6% Propane	38%	46%
Stoddard Solvent	0.9	N/A	2	0.6% Propane	32%	N/A
Tetrahydrofuran (THF)	2.0	1.5	2	0.6% Propane	40%	53%
Tetrahydropyran (THP)	1.6	N/A	6	0.6% Propane	40%	N/A
tert-Butanol	2.4	1.4	2	0.6% Propane	27%	46%
Tetrahyrdothipene (THT)	1.5	1.5	1	2.5% Methane	29%	29%
Triethylamine	1.2	1.2	6	0.6% Propane	36%	36%
Trimethylamine	2.0	2.0	2	0.6% Propane	38%	38%
Vinyl Trimethoxysilane	1.1	N/A	2	0.6% Propane	35%	N/A
Xylenes (O-Xylene)	0.9	0.9	1	2.5% Methane	59%	59%

## 10 Appendix: HART Specific Information

The TG5000 Gas Monitor is available with an optional HART (Highway Addressable Remote Transducer) output communications protocol. With this option, the TG5000 complies with HART Protocol Revision 7.

All available status bytes are defined in the X5000 HART Specification found on the product CD. Refer to that document for complete HART command and status definitions. Use the HART digital interface to query the unit to provide additional troubleshooting information.

*Table 15 Device Identification*

<b>Manufacturer Name</b>	<b>Mine Safety Appliances, Inc (MSA)</b>	<b>Model Name</b>	<b>TG5000</b>
HART ID Code	227 (0xE3)	Device Type Code	46 (0x2E)
HART Protocol Revision	7	Device Revision	1
Number of Device Variables	2		
Physical Layers Supported	FSK		

## 11 Appendix: Modbus RTU Protocol Operation

Connection to X5000 transmitter:

- The 2-Wire RS485 connection terminal is shown to the left of the HART connection



- Connection wire must be Low Capacitance, Shielded data cable, 100-120 Ohm impedance. 1000 feet or 300 meters maximum distance.

### 11.1 Baud Rate

The baud rate is selectable via the Modbus Communications Interface. The selectable baud rates are as follows:

Table 16 Baud Rate

User Select	Baud Rates
0	2400 bits per second

User Select	Baud Rates
1	4800 bits per second
2	9600 bits per second
3	19200 bits per second
4	38400 bits per second
5	115200 bits per second

## 11.2 Data Format

The data format is selectable via the Modbus Communications Interface. The selectable data formats are as follows:

*Table 17 Data Format*

User Select	Data Bits	Parity	Stop Bit	Format
0	8	None	1	8-N-1
1	8	Even	1	8-E-1
2	8	Odd	1	8-O-1
3	8	None	2	8-N-2

Consult Modbus Manual (PN: MANS5000M) for Modbus RTU protocol configuration.

## 12 Appendix: System and Sensor Part List

### TG5000 System

Part #	Description
10236242	TG5000, Polycarbonate, 120/240 VAC, No strobe
10236243	TG5000, Polycarbonate, 120/240 VAC, Red Strobe
10225300	TG5000, Polycarbonate, 120/240 VAC, Red+Amber Strobe
10217888	TG5000, Polycarbonate, 24VDC, No strobe
10217889	TG5000, Polycarbonate, 24VDC, Red Strobe
10217890	TG5000, Polycarbonate, 24VDC, Red+Amber Strobe

### Sensor Assemblies - Select one or two sensors

Gas Type	Gas Code	Full Scale Range	Units	Sensor Type	Part #
CO	10	100	PPM	XCell	10218840
CO	11	500	PPM	XCell	10218841
CO	12	1000	PPM	XCell	10218842
CO	14	100	PPM	XCell	10218843
O2	16	25	% VOL	XCell	10218844
O2	17	Low O2	% VOL	EC	10218845
H2S	20	10	PPM	XCell	10218847
H2S	21	50	PPM	XCell	10218848
H2S	22	100	PPM	XCell	10218849
H2S	23	500	PPM	EC	10218850
H2S	24	20	PPM	MOS	10218851
H2S	25	50	PPM	MOS	10218852
H2S	26	100	PPM	MOS	10218853
H2S	27	10	PPM	DS	10218854
H2S	28	50	PPM	DS	10218855
H2S	29	100	PPM	DS	10218856
Cl2	30	5	PPM	XCell	10218857
Cl2	31	10	PPM	XCell	10218858
Cl2	32	20	PPM	XCell	10218859
CO	36	100	PPM	DS	10218860
CO	37	500	PPM	DS	10218861
CO	38	1000	PPM	DS	10218862
CO	39	100/H2 tol	PPM	DS	10218863
NH3	40	100	PPM	XCell	10218864
NH3	41	1000	PPM	EC	10218865
H2S	42	20	PPM	MOS DS	10218866
H2S	43	50	PPM	MOS DS	10218867
H2S	44	100	PPM	MOS DS	10218868

## Sensor Assemblies - Select one or two sensors

Gas Type	Gas Code	Full Scale Range	Units	Sensor Type	Part #
SO2	50	25	PPM	XCell	10218869
SO2	51	100	PPM	EC	10218870
COMB	60	100	% LEL	XCell	10218871
COMB	61	100	% LEL	XCell	10218872
COMB	62	100	% LEL	XCell	10218873
COMB	63	100	% LEL	XCell	10218874
COMB	64	100	% LEL	XCell	10218875
COMB	65	100	% LEL	XCell	10218876
COMB	66	100	% LEL	XCell	10218877
COMB	67	100	% LEL	XCell	10218878
COMB	68	100	% LEL	XCell	10218879
H2	70	1000	PPM	EC	10218880
NO2	73	10	PPM	EC	10218881
H2S	77	20	PPM	XCell	10218882
H2S	78	50	PPM	XCell	10218883
H2S	79	100	PPM	XCell	10218884
H2S	83	10	PPM	XCell	10218885
H2S	84	50	PPM	XCell	10218886
H2S	85	100	PPM	XCell	10218887
Methane	AA	100	% LEL	IR 5.0	10218888
Propane	AB	100	% LEL	IR 2.1	10218889
Methane	AC	100	% LEL	IR 4.4	10218890
Propane	AD	100	% LEL	IR 1.7	10218891
CO2	AF	2	% VOL	IR	10218893
CO2	AG	5	% VOL	IR	10218894
IPA	CP	100	% LEL	IR	10237167
ETO	CF	100	% LEL	IR	10238493
Hexane	CJ	100	% LEL	IR	10243531
Ethanol	BY	100	% LEL	IR	10243566
Gasoline	CG	100	% LEL	IR	10247370